



XDCAM EX Family

XDCAM EX Camcorder

PMW-EX1

PMW-EX3

XDCAM EX Recording Deck

PMW-EX30

XDCAM EX - A Compact Full-HD Production System With Flash Memory Recording, for an Evolving HD Era

In 2007, Sony introduced the revolutionary XDCAM EX™ handheld camcorder, the PMW-EX1 - the newest member of the Sony XDCAM® family of tapeless production systems - in response to growing demand for an affordable high definition (HD) production solution. This technological breakthrough camcorder - incorporating incredible feature sets such as three 1/2-inch type Full HD CMOS sensors, amazing 1920 x 1080 and 1280 x 720 HD recording capabilities plus flash memory recording in an extremely compact body - was achieved thanks to the extraordinary technical expertise and knowledge amassed when designing Sony's groundbreaking CineAlta™ family of products. Offering striking HD picture quality, extra mobility and great operational efficiency, the PMW-EX1 camcorder has already been rapidly adopted around the world in a broad range of HD production applications and electronic cinematography.

Now Sony evolves the XDCAM EX lineup further still, with the introduction of the PMW-EX3 camcorder and the PMW-EX30 deck. The PMW-EX3 compact camcorder incorporates an eagerly awaited 1/2-inch type interchangeable lens system, providing enhanced creativity and flexibility with a broad choice of lenses. The PMW-EX30 is a compact recording deck that can be used for many different purposes such as recording, viewing, dubbing and source feeding to nonlinear editing systems.

The XDCAM EX products use an SxS PRO™ memory card, which is based on the rapidly growing ExpressCard industry standard, as recording media. Combining the moderate bit rate of MPEG-2 Long GOP compression adopted by XDCAM EX products with the SxS PRO memory card, the XDCAM EX series offers cost-effective long-form recording, coupled to nonlinear capabilities such as instantaneous random access and high-speed file-based operation.

The full Sony XDCAM EX series offers stunning quality HD pictures and efficient nonlinear operation, expanding the possibilities for all types of HD video production at an affordable price.



XDCAM EX Camcorder
PMW-EX1



XDCAM EX Camcorder
PMW-EX3



XDCAM EX Recording Deck
PMW-EX30

XDCAM EX

XDCAM EX – A New Generation of HD Recording System

New Nonlinear Recording Media, SxS PRO Media – For Greater Efficiency and Operability

The XDCAM EX series adopts the SxS PRO™ memory card for its recording media. It was developed specifically for professional content-creation applications, and is based on the SxS PRO memory card specification. The SxS PRO memory card is an ultra-compact nonlinear medium that uses flash memory with a number of distinguishing features:



SxS

- Compatible with ExpressCard/34 standard
- Uses PCI Express interface, and achieves an extremely high data transfer speed of 800 Mb/s*
- Large storage capacity: 8-GB, 16-GB, and 32-GB memory cards are available.
- Can record up to 140 minutes of HD video and audio (using one 32-GB memory card)
- Most new Macintosh and PC computers are equipped with ExpressCard slots
- Compact size: approx. 3 x 1 3/8 x 7/32 inches (75 x 34 x 5 mm) (excluding the projecting parts) – about half the size of a conventional PC card
- Low power consumption

*This data read speed is measured with benchmark software. Actual data transfer speeds vary according to measurement conditions. Please refer to <http://www.sony.net/SxS-Support/> for information on measuring methods.

**Early PMW-EX1 camcorders require an upgrade to use the 32-GB memory card. Please contact your Sony service representative for further details.

1920 x 1080 HD Recording Using the “MPEG-2 Long GOP” Codec

The XDCAM EX products record 1920 x 1080 HD images using the “MPEG-2 Long GOP” codec, which conforms to the MPEG-2 MP@HL compression. This highly efficient “MPEG-2 Long GOP” codec – that is also adopted in the XDCAM HD and HDV™ 1080i series of products – enables users to record stunning-quality HD video and audio over a long period of time by efficiently compressing the data.



		HQ Mode	SP Mode
Video Codec	Compression	MPEG-2 Long GOP	MPEG-2 Long GOP
	Sampling	4:2:0	4:2:0
	Bit Rate	35 Mb/s VBR	25 Mb/s CBR
Image Resolution		1920 x 1080	1440 x 1080
		1280 x 720	

Selectable Bit Rates

The XDCAM EX products offer a choice of bit rates – either 35 Mb/s (HQ mode) or 25 Mb/s (SP mode) – depending on the desired picture quality and recording time. The HQ mode supports both 1920 x 1080 and 1280 x 720 resolutions. The SP mode supports 1440 x 1080 resolution at 25 Mb/s, which provides compatibility with HDV 1080i products. Footage recorded in the SP mode can be seamlessly integrated into HDV-compatible editing systems by connecting the camcorder via the i.LINK®* (HDV) interface. It can also be recorded on XDCAM HD's optical disc through the use of the supplied Clip Browser software.

*i.LINK is a trademark of Sony Corporation used only to designate that a product contains an IEEE 1394 connector. Not all products with an i.LINK connector will necessarily communicate with each other. For information on compatibility, operating conditions and proper connection, please refer to the documentation supplied with any device with an i.LINK connector. For information on devices that include an i.LINK connection, please contact your nearest Sony office or authorized dealer.

Long Recording Time

Combining the moderate bit rates produced by efficient MPEG-2 Long GOP compression and the large-capacity SxS PRO memory card, XDCAM EX products record high-quality HD images for a long recording time of approximately 140 minutes on a single 32-GB SxS PRO memory card (in SP mode)*. Equipped with two SxS PRO memory card slots, XDCAM EX products achieve up to 280 minutes of recording using two 32-GB memory cards in SP mode and up to 200 minutes in HQ mode.

When a clip spans two cards, the transition is seamless without any artifacts or frame loss. The SxS PRO memory card can be hot-swapped while shooting, without interrupting the recording. This feature makes XDCAM EX products ideal for a wide variety of long-form content-production applications.

Recording Time (approx.)** (on 32-GB memory card)	HQ, 35 Mb/s VBR	100 minutes
	SP, 25 Mb/s CBR	140 minutes

*Early PMW-EX1 requires an upgrade to use the 32-GB memory card. Please contact your local Sony Authorized service representative for further details.

**When recording in HQ (35 Mb/s) mode, the recording time may differ from the above specified figure depending on the actual bit rate that is adopted during VBR encoding.



Multiple-format Recording - 1080/720 and Interlace/Progressive Switchable Operation

The XDCAM EX deck and camcorders offer a wide array of recording formats for multiple content-creation applications. Recording mode is switchable between 1920 x 1080, 1280 x 720, and 1440 x 1080 resolution. The scanning system is also selectable from interlace and progressive, such as 59.94i, 50i, 59.94P, and 50P. In addition, XDCAM EX camcorders* offer native 23.98P progressive recording in 1920 x 1080, and 1280 x 720 modes, while the XDCAM EX deck** offers 23.98P in 1920 x 1080 mode. The PMW-EX30 supports the REC function in 29.97P/25P/23.98P mode and the EE/PB function in 29.97PsF/25PsF/23.98PsF mode through HD-SDI input/output**. XDCAM EX camcorders do not support the PB function but do support the EE function in 23.98PsF mode.

	XDCAM EX Camcorders		XDCAM EX Deck	
	NTSC Setting	PAL Setting	NTSC Setting	PAL Setting
1920 x 1080 (HQ Mode)	59.94i, 29.97P, 23.98P	50i, 25P	59.94i, 29.97P**, 23.98P**	50i, 25P**
1280 x 720 (HQ Mode)	59.94P, 29.97P, 23.98P	50P, 25P	59.94P	50P
1440 x 1080 (SP Mode)	59.94i*	50i	59.94i	50i

The SxS PRO memory card can simultaneously hold a mix of multiple files of any of these recording formats, allowing flexible use of the memory card.

*On the XDCAM EX camcorder, images in 1440 x 1080/23.98P (SP) mode are handled as 23.98P and recorded as 59.94i signals via 2-3 pull-down.

**Early PMW-EX30 requires an upgrade to achieve these capabilities. Please contact your local Sony service representative for further details.

High-quality Uncompressed Audio Recording

In addition to HD video recording, high-quality audio is an equally significant feature in the XDCAM EX products. The XDCAM EX camcorders and deck record and play back high-quality, two-channel 16-bit, 48-kHz linear PCM uncompressed audio.

Compression	None (Linear PCM)
Number of Channels	2 channels
Sampling Frequency	48 kHz
Quantization	16 bits/sample

Instant-access Thumbnail Search With "Expand" Function

Each time a recording is started and stopped on the XDCAM EX products, the video and audio signals are recorded as one clip. During playback, users can cue-up to the next or previous clip simply by pressing the "Next" or "Previous" button, as you would do on a CD or DVD player. Furthermore, thumbnails are automatically generated for each clip as a visual reference, allowing operators to cue-up to a desired scene simply by guiding the cursor to a thumbnail and pressing the "Play" button. For further convenience, the "Expand" function allows one selected clip in the Thumbnail display to be divided into 12 even-time intervals, each with their own thumbnail identifier. This is useful if an operator wanted to quickly search for a particular scene within a lengthy clip.

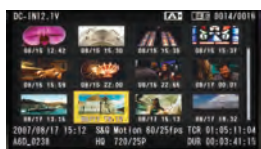

IT Friendly

With the XDCAM EX products, recordings are made as data files in the "MP4" format, which has been standardized by ISO. The file-based recording allows material to be handled with great flexibility in an IT-based environment for copying, transferring, sharing, and archiving. Those operations are accomplished lossless without any "re-digitizing" process. The recording system also allows for material to be viewed directly on a PC by inserting the SxS PRO memory card into the ExpressCard™ slot on a PC, or by linking a PC to the Utilizing the supplied Clip Browser Version 2 and compatible non-linear editing software, the user can view, edit, and search metadata. This helps to improve workflow efficiency.

High Reliability

The SxS PRO memory card can resist shock (1500 G) and vibration to (15 G). Adopting a memory recording system, the unit's mechanism is simplified. Also, a unique "salvage" function can restore content that has been damaged by power loss or memory disconnection during recording*.

*In some cases, images recorded just before the accident may not be restored (4 seconds maximum).

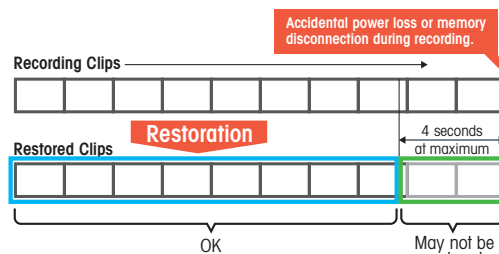

No Accidental Overwriting of Footage, Immediate Recording Start

By virtue of recording on flash memory card, the XDCAM EX products make each new recording on an empty area of the card. This is extremely convenient, as camera operators do not have to worry about accidentally recording over good takes, and they don't have to search through footage for the correct position to start the next recording. In short, it means the camera is always ready for the next shot!

Metadata

XDCAM EX products are capable of recording a variety of metadata, which provides a huge advantage when searching for specific data after an initial recording has been made. Information such as production dates, creator names, video format, and camera settings can be saved together with the AV material. This makes it possible to organize and search through all recordings effectively. One particular metadata, called Shot Mark, is a convenient reference that can be added to desired frames to make them easy to recall in the subsequent editing process. Utilizing supplied Clip Browser Version 2.0, the XDCAM EX Clip Browsing Software, the user can view, edit, and search metadata. This helps to improve workflow efficiency.

XDCAM EX Camcorders

PMW-EX1

PMW-EX3



PMW-EX1



PMW-EX3

The shotgun microphone is an optional accessory.

The XDCAM EX series offers a choice of two HD camcorders. One is the PMW-EX1 handheld camcorder with a fixed-type zoom lens. The other is the new PMW-EX3, a compact camcorder with an interchangeable lens system.

Both camcorders incorporate three 1/2-inch type Exmor™ Full HD CMOS Sensors, each with an effective pixel count of 1920 x 1080, delivering stunning-quality HD images in 1080P, 720P and 1080i HD resolutions. The frame rate of these camcorders is selectable from interlace and progressive, such as 59.94i, 50i, 59.94P, 50P, 29.97P, 25P and native 23.98P recording.*

A rich variety of features for creative shooting are incorporated into these camcorders such as "Slow & Quick Motion", which is also commonly known as "over-cranking" and "under-cranking", selectable gamma curves, slow-shutter, interval recording and Picture Profile™ feature.

Additionally, the PMW-EX3 camcorder offers a convenient remote-control and multi-camera operation capability, which allows use with high-end camera systems.

*59.94P and 50P recording are available in 1280 x 720 mode. In 1440 x 1080/23.98P mode, images are handled as 23.98P and recorded as 59.94i signals via 2-3 pull-down.

Cutting-edge Camera Technology

1/2-inch type Three Exmor Full HD CMOS Sensors

The XDCAM EX camcorders are equipped with three newly developed 1/2-inch type Exmor CMOS Sensors, each with an effective pixel count of 1920 (H) x 1080 (V), which delivers excellent picture performance with full HD resolution. This 1/2-inch type image sensor, with Sony's accumulated sensor technologies, allows the camcorder to provide an excellent sensitivity of F10, a remarkable signal-to-noise ratio of 54 dB, and high horizontal resolution of 1000 TV lines*.

It also greatly reduced power consumption and associated heat dissipation of the XDCAM EX camcorders, which made possible the unique use of 1/2-inch type sensors on the compact camcorder. In addition, this large 1/2-inch type image sensor can capture images with a shallower depth of field than all other handheld camcorder's smaller-size image sensors, giving users more creative freedom of expression.

*In HD-SDI, HQ 1080 mode

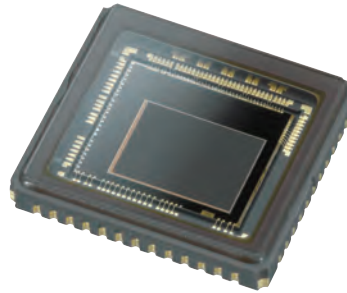

Exmor
FULL HD 3CMOS

Lens Choices

Interchangeable Lens System (PMW-EX3 Only)

The PMW-EX3 camcorder incorporates a newly developed 1/2-inch type "EX mount" interchangeable lens system that allows the lens to be as compact and lightweight as possible while maintaining its high optical performance. If a wide-angle lens is needed, the Fujinon 1/2-inch type XS8X4AS-XB8, which also has an EX mount, is available. This mount system allows a variety of 1/2-inch type HD lenses available from major manufacturers to be used with the PMW-EX3 camcorder via the supplied lens adaptor, expanding the spectrum of creative expressions.* A 2/3-inch-type lens** can also be used with the PMW-EX3 camcorder via the mount system by using a 2/3-inch type lens adaptor*** that is equipped with a 12-pin lens connector. This illustrates the breadth of lens choice, including even cinema-style lenses, to suit every specific shooting requirement.

*This 1/2-inch type lens adaptor supplied with the PMW-EX3 camcorder is equipped with the hot shoe lens mount connector only. Automatic lens iris control can work only with a lens with hot shoe connectors. Some lens functions are not supported by the PMW-EX3. For more details, please contact each lens manufacturer.

**In this configuration, the resulting focal length will be 1.37 times the actual focal length of the lens.

***When using 2/3-inch type lenses with the PMW-EX3 camcorder, the Fujinon ACM-21 lens mount adaptor must be used.



Supplied EX mount lens



Supplied 1/2-inch type lens adaptor (L0-3830)

1/2-inch type lens

Supplied Wide-angle Fujinon 14x Zoom Lens

The XDCAM EX camcorders are equipped with a high-quality, high-definition Fujinon 14x zoom lens specifically designed for the XDCAM EX camcorder to offer optimum picture performance and unprecedented functionality. It offers a wide angle of view of 5.8 mm (equivalent to 31.4 mm on a 35 mm lens), and many convenient features for diverse shooting situations.

Unique Focus Operation

Unique Focus Operation – Professional Manual Focus and Auto Focus

The lens adopts a newly developed and unique focus ring mechanism, which offers two types of manual focus, plus an auto focus operation. The lens is equipped with two independent focus wheel mechanisms, which can be switched by sliding the focus ring itself back and forth. When the focus ring is in the front position, the lens works in the same way as a typical auto focus lens on a handheld camcorder. In this case, either manual or auto focus mode can be selected by the AF/MF switch on the lens. On the other hand, when the focus ring is set to the back position, the lens has an absolute focus position, and works in the same way as interchangeable-lens, which professional users are familiar with.



Front : AF/MF

Back : Full MF

AF/MF Mode

- Full AF
- One-push AF
- MF
- AF/MF Assist

Full MF Mode

- Full MF (absolute focus position)

Three Independent Rings

In addition to the unique focus ring, the lens is equipped with independent rings for zoom and iris adjustment; all have physical stops and absolute markings permitting precise adjustments. The location, rotational range and feel are identical to other manual high-end HD lenses. This gives users a high level of familiarity and operational comfort.



Optical Image Stabilizer

To minimize the blurring effect caused by hand-shake, the lens incorporates an optical image stabilizer function that provides highly stable images.

AF Assist

The AF (Auto Focus) Assist function of the XDCAM EX camcorders enables operators to manually change focus positions using the focus ring during AF mode. This means that AF reference focus positions can be positively shifted manually to a new position.

MF Assist

The MF (Manual Focus) Assist function of the XDCAM EX camcorders helps to precisely focus on the target subject when shooting in MF mode. When the MF Assist is enabled, the auto focus is momentarily activated when the user stops adjusting the focus ring. The camera will then finely focus on the subject closest to the focal point of the lens at that time.

Expanded Focus

At the touch of a button, the center of the screen on the LCD monitor and viewfinder of the XDCAM EX camcorders can be magnified to about twice the size, making it easier to confirm focus settings during manual focusing.

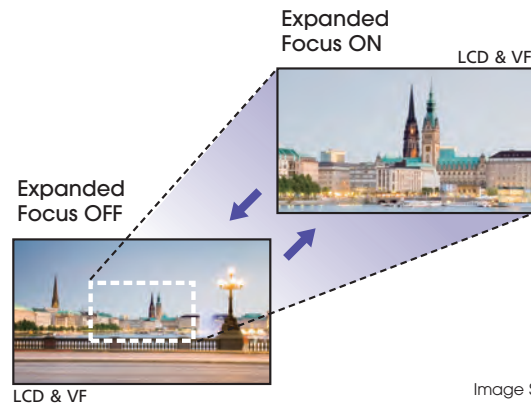

Image Simulated

Selectable Peaking

The Peaking function of the XDCAM EX camcorders can help operators to quickly and accurately adjust the camera's focus by altering the way pictures are displayed on the LCD monitor and viewfinder. It can enhance the outline of the image which the camera focuses on most, and changes its color to make it stand out. Enhance levels can be selected from a choice of "HIGH", "MIDDLE", and "LOW", and the outline color from "RED", "WHITE", "YELLOW", and "BLUE".



Peaking OFF

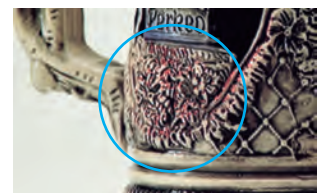

Peaking ON

Creative Recording Modes and Settings

23.98P Native Recording



The XDCAM EX camcorders, a member of Sony's legendary CineAlta family, offer the native 23.98P* recording capability on its handy body. This feature, accompanied with other creative features makes the camcorder ideal for cinema production.

*On the XDCAM EX camcorder in 1440 x 1080/23.98P (SP) mode, images are handled as 23.98P and recorded as 59.94i signals via 2-3 pull-down.

Slow & Quick Motion Function

The XDCAM EX camcorders offer a powerful Slow & Quick Motion function – commonly known as over-cranking and under-cranking by filmmakers – that enables users to create unique 'looks' or slow- and fast-motion special effects.

The XDCAM EX camcorders can capture images at frame rates selectable from 1 fps (frame per second) to 60 fps in 720P mode and from 1 fps to 30 fps in 1080P mode, in increments of 1 fps.

For example, when viewed at 23.98P, images captured at 60 fps will appear 2.5 times slower than normal. Conversely, images captured at four fps will appear six times faster than normal.

With the Slow & Quick Motion function of this camcorder, images are recorded natively with no padded frames and at full resolution. The obtained quality of the slow- and fast-motion images is extremely high from those created in the editing process.

In addition, these slow- and quick-motion images can be played back immediately after shooting, without using any converters or processing on nonlinear editing systems.

Slow Motion Mechanism

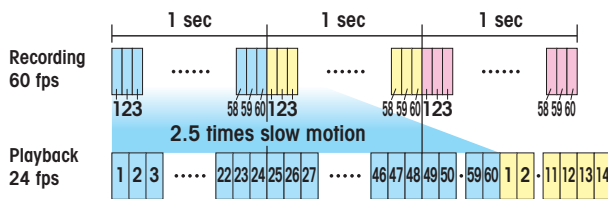

Slow Shutter Function

The XDCAM EX camcorders offer a Slow Shutter function for capturing clear images in low-light environments. The Slow Shutter function not only increases camera sensitivity but also produces a special blurring effect when shooting a moving object, for enhanced shooting creativity. The shutter speed is selectable from 2-, 3-, 4-, 5-, 6-, 7-, 8-, 16-, 32-, and 64-frame accumulation periods.

Selectable Gamma Curves

The XDCAM EX camcorders offer a wide variety of gamma curves to flexibly handle contrast, and give a specific 'look' to an image. In addition to four types of standard gamma curves, the XDCAM EX camcorders provide four types of CINE Gamma (CINE 1, 2, 3, and 4), which are identical to those on high-end CineAlta camcorders. Operators can select the best-suited preset gamma curve depending on scenes.

CINE Gamma Curves

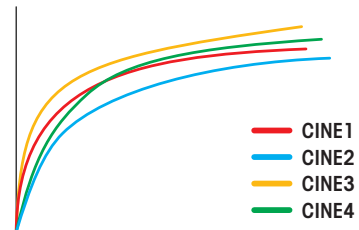

Interval Recording Function

The XDCAM EX camcorders offer an Interval Recording function that records one frame at pre-determined intervals. This is convenient for shooting over long periods of time, and also when creating special effects of extremely quick motion.

Frame Recording Function

Frame Recording is a unique feature of the XDCAM EX camcorders that is especially useful for clay animation shooting. Using this function, images for pre-determined frames are recorded every time the Record button is pressed.

Shutter Angle Settings

In addition to traditional electronic shutter speed controls adjustable in fractions of a second, the XDCAM EX camcorders also have a "shutter angle" control – which is familiar to filmmakers. By setting the shutter adjustment mode to "angle", the XDCAM EX camcorders automatically set the proper exposure time, based on the selected frame rate and shutter angle.

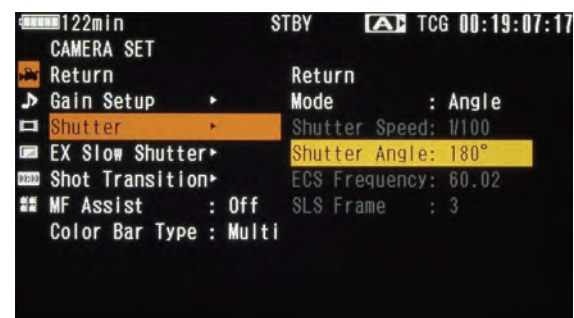

Operational Versatility

Picture Profile Feature

The Picture Profile feature of the XDCAM EX camcorders allow camera operators to easily call up customized picture-tonal settings to suit particular shooting conditions, rather than having to readjust the camera each time – giving users greater operational efficiency. Up to six different picture-tonal settings such as the parameters of matrix, color correction, detail, gamma, and knee can be saved in the memory. These settings are displayed on the LCD monitor at the touch of a button.

Shot Transition function

The Shot Transition™ function of the XDCAM EX camcorders, with a simple push of a button, allows for smooth, precise and repeatable automatic scene transitions to occur. The operator can program the duration and select from three transition profiles: Linear, Soft Stop, or Soft Transition. Many lens parameter such as the start and end settings for zoom, focus, and/or camera parameters such as white balance and gain can be programmed to transition in unison. It works by automatically calculating the

intermediate values during the scene transition.

The Shot Transition function can be triggered manually or synchronized with the camera's REC start function. The transition progress can be checked on a bar graph on the LCD monitor. In addition, a start timer function is also available for the Shot Transition function, helping to prevent operators from missing a shot. This function is very useful when precise, simple or complex changes to the lens or camera settings are required during the scene – for example, when changing the focus from the background to the foreground of a scene.



1 Depth-of-field Indicator

A Depth-of-field graphic can be displayed on the LCD monitor and viewfinder of the XDCAM EX camcorders to help camera operators easily read the actual depth-of-field of a scene, and assist setting up the lens and exposure for optimum depth-of-field control.

Shallow Depth of Field

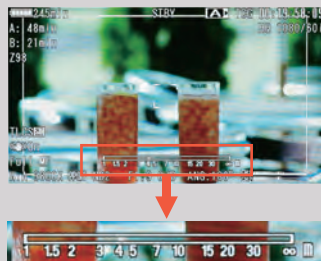

Deep Depth of Field



2 Brightness-level Display

The average brightness level of the center of a frame can be displayed on the LCD monitor and viewfinder of the PMW-EX1 camcorder, or on the LCD viewfinder of the PMW-EX3 camcorder as a percentage. This is useful when a waveform monitor is not available for shooting.



3 Histogram Indicator

The Histogram Indicator can be displayed on the LCD monitor and viewfinder of the PMW-EX1 camcorder or on the LCD viewfinder of the PMW-EX3 camcorder, allowing operators to easily evaluate the distribution of brightness of the currently captured images. This enables proper exposure control of iris, gain, and gamma.

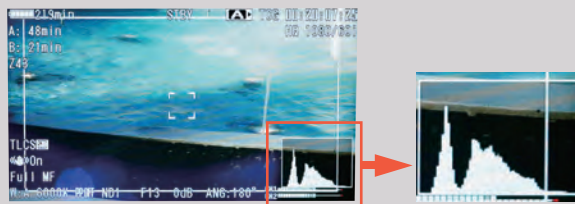

A 3.5-inch* Color LCD Screen

The XDCAM EX camcorders are equipped with a newly developed, large, easy-to-view, color LCD screen with a high resolution of 1920 x 480 pixels. The LCD screen of the XDCAM EX camcorders can be flexibly rotated for accessible viewing from any shooting angle. The ease of focusing offered by this high resolution panel, location and adjustability permits using it as a viewfinder or camera assistant operator panel. It can also be used to instantly review recorded footage, as well as access the camera's set-up menus and view thumbnails, display status indications such as audio meters, depth-of-field indicators, remaining memory capacity and battery time. What's more, the use of the hybrid LCD screen - which comprises transmissive and reflective panels - offers clear viewing in both studio and "full sun" field shooting conditions.

*Viewable area measured diagonally.

PMW-EX1



PMW-EX3



B Four Assignable Buttons

Frequently used functions can be programmed onto four assignable buttons on the XDCAM EX camcorders, allowing operators to make rapid changes when working in the field. These can be functions such as ATW, Freeze Mix, Rec Review, Expanded Focus, Depth-of-field indicator, and more.



C 0.54-inch* Color LCD Viewfinder (PMW-EX1 Only)

The 0.54-inch color LCD viewfinder of the PMW-EX1 camcorder displays high-resolution color pictures of approximately 250,000 pixels in a wide-screen aspect ratio of 16:9. Operators can switch the display mode between color and monochrome according to their preference.

*Viewable area measured diagonally.

D On-handle Zoom Switch and REC Start/Stop Button

In order to facilitate zoom control and recording operation during low-angle shooting, an additional zoom switch and record start/stop button are located on the carrying handle of the XDCAM EX camcorders.



E Rotary Grip

The hand grip of the XDCAM EX camcorders can rotate approximately 120 degrees, which allows camera operators to flexibly adjust the angle of the grip. This gives users greater control and comfort when holding the camera from any shooting position.



F Built-in Stereo Microphone and Two-channel Audio Input

The XDCAM EX camcorders come equipped with a built-in stereo microphone and two XLR audio input connectors for connecting professional microphones or feeding an external-line audio source. These allow high-quality, two-channel 16-bit, 48-kHz linear PCM uncompressed audio to be recorded on the XDCAM EX camcorder.

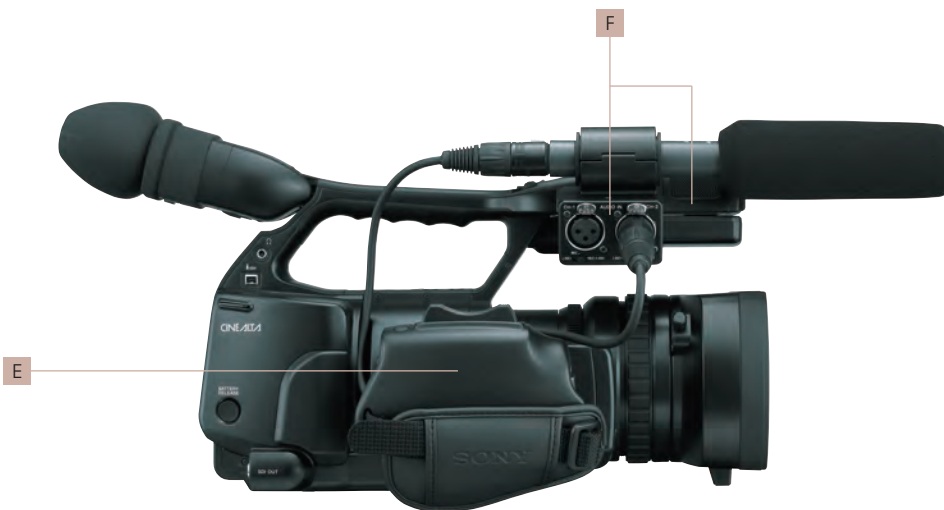

PMW-EX1



PMW-EX3

HD-SDI and other versatile interfaces

XDCAM EX camcorders come equipped with a wide range of interfaces optimized for a variety of operational needs, wide interoperability, and flexible workflow. These include an HD-SDI output and, in E-to-E mode, 10 bits of 4:2:2 signal can be output from the connector. The high-quality picture can be utilized as the source signal in the chroma key process or for various other purposes. For versatile usage, there is also a down-converted SD-SDI output, i.LINK (HDV) input/output, and analog composite/component output. Additionally, the PMW-EX3 camcorder is equipped with a Timecode input/output and Genlock input, allowing the camcorder to be used in a multi-camera system.

Interfaces

	PMW-EX1	PMW-EX3
Input	External MIC/LINE (XLR)	
	–	Timecode (BNC)
	–	Genlock (BNC)
Output	HD-SDI or SD-SDI (BNC)	
	Component (Mini D)	
	–	Composite (BNC)
	A/V (A/V multi): Composite, S-Video, Audio	–
	–	S-Video
	–	Audio (RCA)
	–	Timecode (BNC)
Others	i.LINK (HDV in/out)	
	USB	
	–	Remote (8-pin)

PMW-EX1



PMW-EX3



Camera Remote Control (PMW-EX3 Only)

The PMW-EX3 camcorder comes equipped with a remote control interface. Various camera settings can be remotely controlled using an optional RM-B150 or RM-B750 Remote Control Unit via its 8-pin remote connector.*

*Some controls on the RM-B150/B750 are not supported by the PMW-EX3 camcorder.



RM-B150

RM-B750

Adjustable Shoulder Pad and Cheek Pad (PMW-EX3 Only)

The position of the shoulder pad of the PMW-EX3 camcorder can be selected from two positions. In addition, the PMW-EX3 camcorder is supplied with a detachable cheek pad. Operators can always attain a comfortable and well-balanced camera position, even when the camcorder is docked with long lenses.



Other Features

- ATW (Auto Tracing White Balance)
- Built-in ND filter wheel: OFF: Clear, 1: 1/8ND, 2: 1/64ND
- Selectable gain: -3, 0, 3, 6, 9, 12, 18 dB
- High-speed picture search: x4, x15
- Freeze Mix function
- Skin-tone Detail control
- Low-key saturation
- IR Remote Commander® unit



XDCAM EX Recording Deck PMW-EX30



The PMW-EX30 deck is a highly versatile and affordable compact recording deck, and can be used for many different applications. It allows simple viewing of recorded materials with a monitor, dubbing to other format/media such as HDV, XDCAM HD and HDCAM®, and feeding to nonlinear editing systems. In addition, the PMW-EX30 deck can be used as an affordable full HD recorder for event recordings - it can record HD signal outputs from a switcher.

The PMW-EX30 deck is equipped with a wide array of interfaces including HD-SDI input and output, HDMI output, HD analog component, composite outputs and more. Equipped with two SxS PRO memory card slots, the PMW-EX30 deck can record approximately 280 minutes of HD footage using two 32-GB SxS PRO memory cards.*

*In SP mode

Features

- Highly compact design - can be placed either horizontally or vertically
- MPEG HD recording and playback at 35 and 25 Mb/s
- Equipped with two SxS PRO memory card slots
- Built-in 3.5-inch* LCD monitor
- Comprehensive range of HD interfaces - HD-SDI input/output, i.LINK (HDV) input/output and component output
- Supports the recording and playback in 29.97P/25P/23.98P mode, and 29.97PsF/25PsF/23.98PsF signal handling through the HD-SDI input/output*

- Down-converted SD outputs for migration to SD environments - SD-SDI, i.LINK (DVCAM), component, S-Video, and composite
- HDMI output for digital connection to a range of consumer displays
- Adjustable audio input volume (CH1 and CH2)

*Viewable area measured diagonally.

Recording Format

	NTSC setting	PAL setting
1920 x 1080 (HQ mode)	59.94i, 29.97P*, 23.98P*	50i, 25P*
1280 x 720 (HQ mode)	59.94P	50P
1440 x 1080 (SP mode)	59.94i	50i

* Early PMW-EX30 requires an upgrade to achieve these capabilities. Please contact your local Sony Authorized service representative for further details.



Examples of how to use the stands



Rear

XDCAM EX Application Software

The XDCAM EX products come with two application software packages that provide powerful yet easy and intuitive management of recorded content. Included are two versions of Clip Browser (Macintosh and PC versions) as well as the XDCAM Transfer application software for Apple Final Cut Pro™ nonlinear editing systems.



Clip Browser Version 2

The Clip Browser software for the XDCAM EX products is a simple-to-use PC application software that allows users to easily browse and copy video clips recorded by the XDCAM EX camcorder or deck to other devices such as hard disk drives. It also serves as a bridge tool between a variety of formats - converting XDCAM EX clips to be other file formats. The Clip Browser software is available for both Windows-based PCs and Macintosh computers.

Features

- Browsing of video clips recorded by the XDCAM EX products
- Copy XDCAM EX's clip files from the SxS PRO memory card to hard disk drive
- Combine segmented clips recorded across two SxS PRO memory cards
- File format conversion from MP4 to other file formats:
 - > MXF format for export to XDCAM HD discs or MXF-based nonlinear editing systems* (option)
 - > DV format for export to DV-based nonlinear editing systems
 - > AAF format for export to Avid nonlinear editing systems
 - > H.264/AVC format for field viewing on Sony PSP™, Apple iPod™/iPhone as well as WMV format* (option)
- Create sub clips with Mark IN/OUT operation
- Registration of metadata such as "title", "creator" and "comments" for a clip
- Registration of "Shot Mark" metadata for instant cue-up to desired scenes
- Capture and create a still image file (BMP) for a desired scene

*Requires an optional plug-in software supplied from MainConcept AG. (<http://www.mainconcept.com/plugin4clipbrowser>)



System Requirements

Windows OS (32-bit version):
Windows XP™ Home Edition (Service Pack 2 or later)
Windows XP Professional (Service Pack 2 or later)
Windows Vista Ultimate (Service Pack 1 or later)
Windows Vista Business (Service Pack 1 or later)
Windows Vista Home Premium (Service Pack 1 or later)
Windows Vista Home Basic (Service Pack 1 or later)

CPU:
Intel Pentium IV Processor 1.2 GHz or higher (minimum)
Intel Core 2 Duo 2 GHz or higher (recommended)

RAM:
Windows XP: 512 MB (minimum), 1 GB (recommended)
Windows Vista™: 1 GB (minimum), 2 GB (recommended)

Mac OS:
Mac OS X version 10.4.11 or later (including "Leopard")

CPU:
Intel Core 2 Duo 2 GHz or higher (recommended)

RAM:
1 GB (recommended)



Clip Browser GUI (Windows)



Clip Browser GUI (Macintosh)

PDZK-P1* Ver. 2.8 XDCAM Transfer for Apple Final Cut Pro Nonlinear Editing System

The PDZK-P1 XDCAM Transfer is plug-in software for Apple Final Cut Pro nonlinear editing systems that provides support for MP4 files recorded by XDCAM EX systems. With this software installed on a Macintosh computer, the XDCAM EX products or SxS PRO memory card can be mounted on Mac Finder directly, and users can seamlessly import and edit recorded material. Additionally, the new Ver. 2.8 enables to export edited material to XDCAM EX MP4 files.

*The latest version of this software can be downloaded from Sony websites. Please contact your nearest Sony office or Authorized XL Reseller for further information.



System requirements

OS:
Mac OS X 10.4.11 or later (including "Leopard")

CPU:
Intel Core 2 Duo 2 GHz or higher
Intel Xeon 2 GHz or higher
PowerPC G5 2 GHz

RAM:
1 GB or more

Optional Accessories

PHU-60K Professional Hard Disk Unit

The PHU-60K* is an external storage unit for XDCAM EX products that allows XDCAM EX clips to be recorded on its large-capacity 60-GB hard disk drive for up to approximately 200 minutes in HQ mode and 260 minutes in SP mode.

- Large storage capacity of 60 GB
- Long recording time:
> Approximately 200 minutes in HQ mode and 260 minutes in SP mode
- Can be easily attached to the XDCAM EX camcorder using the supplied shoe adaptor and cable (PHU connection cable)**
- Can be easily attached to the PMW-EX30 deck using the supplied cable (PHU connection cable)

*The PHU-60K does not support Slow & Quick Motion recording.

**With early PMW-EX1, a software upgrade may be required to use PHU-60K. Please contact your nearest Sony office or Authorized XL Reseller for further information.

*** PHU-60K is available through Authorized Sony Media Resellers.



SBAC-US10 SxS Memory Card USB Reader/Writer

The SBAC-US10 is an SxS PRO memory card reader/writer that works on both Windows-based PCs and Macintosh computers via a USB 2.0 interface. This compact and portable device comes in handy in many situations such as in location, desktop browsing and full-fledged editing.



BC-U2* Battery Charger

The BC-U2 is a battery charger that can charge two batteries simultaneously. It can also supply the power for a camcorder during charging for a battery.

*This model is expected to be available in Spring 2009.



Optional Accessories

SBP-32/16/8
SxS PRO Memory Cards



BP-U30
Lithium-ion Battery Pack
(28 Wh)



BP-U60
Lithium-ion Battery Pack
(56 Wh)



BC-U1
Battery Charger
(for BP-U30/U60)



VCL-719BXS/B*
19x Focus Servo Lens
(for PMW-EX3)



VCL-EX0877
0.8x Wide Conversion Lens
(for PMW-EX1)



RM-B150
Remote Control Unit
(for PMW-EX3)



RM-B750
Remote Control Unit
(for PMW-EX3)



ECM-673
Shotgun-type Electret
Condenser Microphone

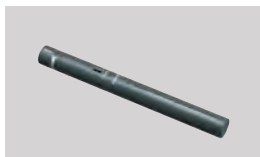

UWP-V1
UHF Wireless Microphone
Package



UWP-V2
UHF Wireless Microphone
Package



UWP-V6
UHF Wireless Microphone
Package



URX-P2
UHF Diversity Tuner



*The lens mount adaptor supplied with the PMW-EX3 camcorder is required to attach this lens to the PMW-EX3.

1/2-inch Type HD Lenses From Other Manufacturers

Canon
KH20x6.4 KRS*



Canon
KH13x4.5 KRS*



Fujinon
XS17x5.5BRM/BRD*



Fujinon
XS13x3.3BRM/BRD*



Fujinon
XS8X4AS-XB8
(EX Mount Wide-angle Lens)



*Requires the 1/2-inch lens mount adaptor (L0-3830) supplied with the PMW-EX3 camcorder to attach these lenses to the PMW-EX3. Some lens functions are not supported by the PMW-EX3 camcorder. For details of the lenses, please contact each lens manufacturer.

Other Lens Accessory

Fujinon
ACM-21*

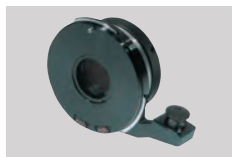

*When using 2/3-inch type lenses with the PMW-EX3 camcorder, the Fujinon ACM-21 lens mount adaptor must be used. For details, please contact the lens manufacturer.

Camcorder System Diagrams

Unless specified as "supplied", all the components below are optional.

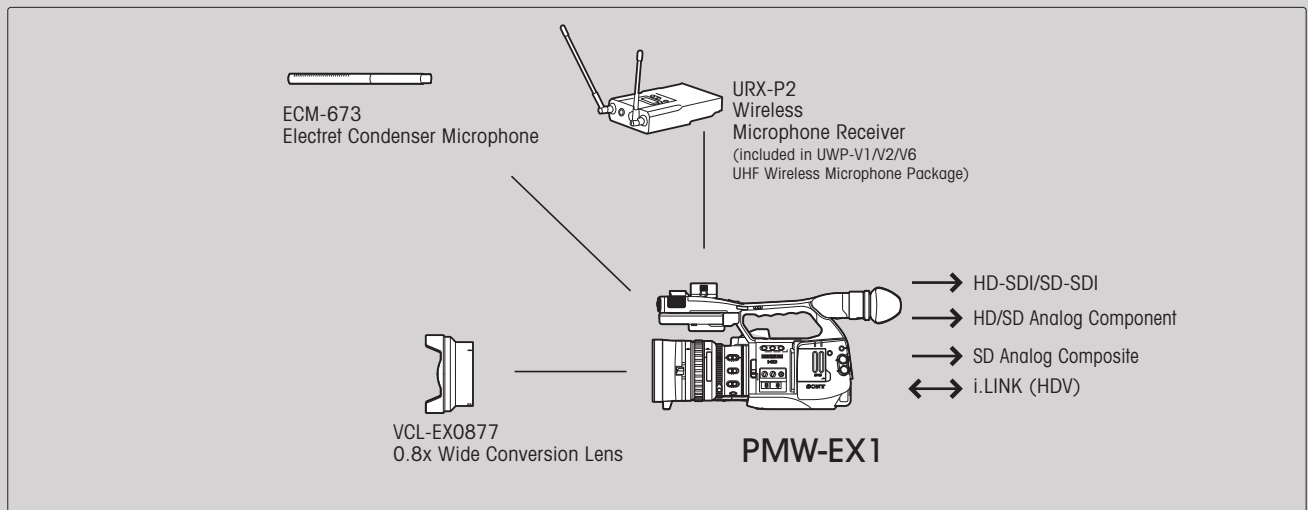
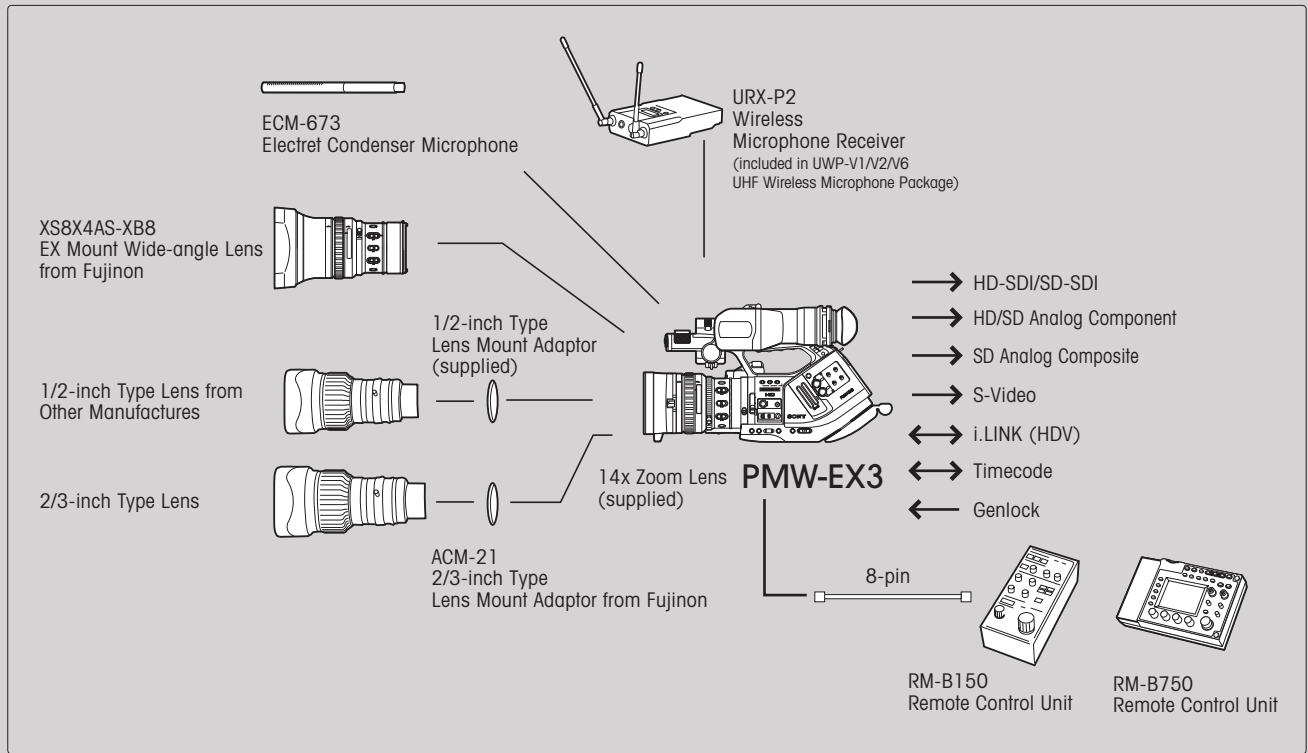

Battery Charger

BC-U1 Battery Charger/
AC Adaptor (supplied)

BC-U2 Battery Charger/
AC Adaptor

Battery

BP-U30 Lithium-ion Battery Pack
(supplied)

BP-U60 Lithium-ion Battery Pack
(supplied)

Remote Commander Unit

Remote Commander Unit
(supplied)

Recording Media

SBP-8 **SBP-16** **SBP-32**

Workflow Examples

Ingest

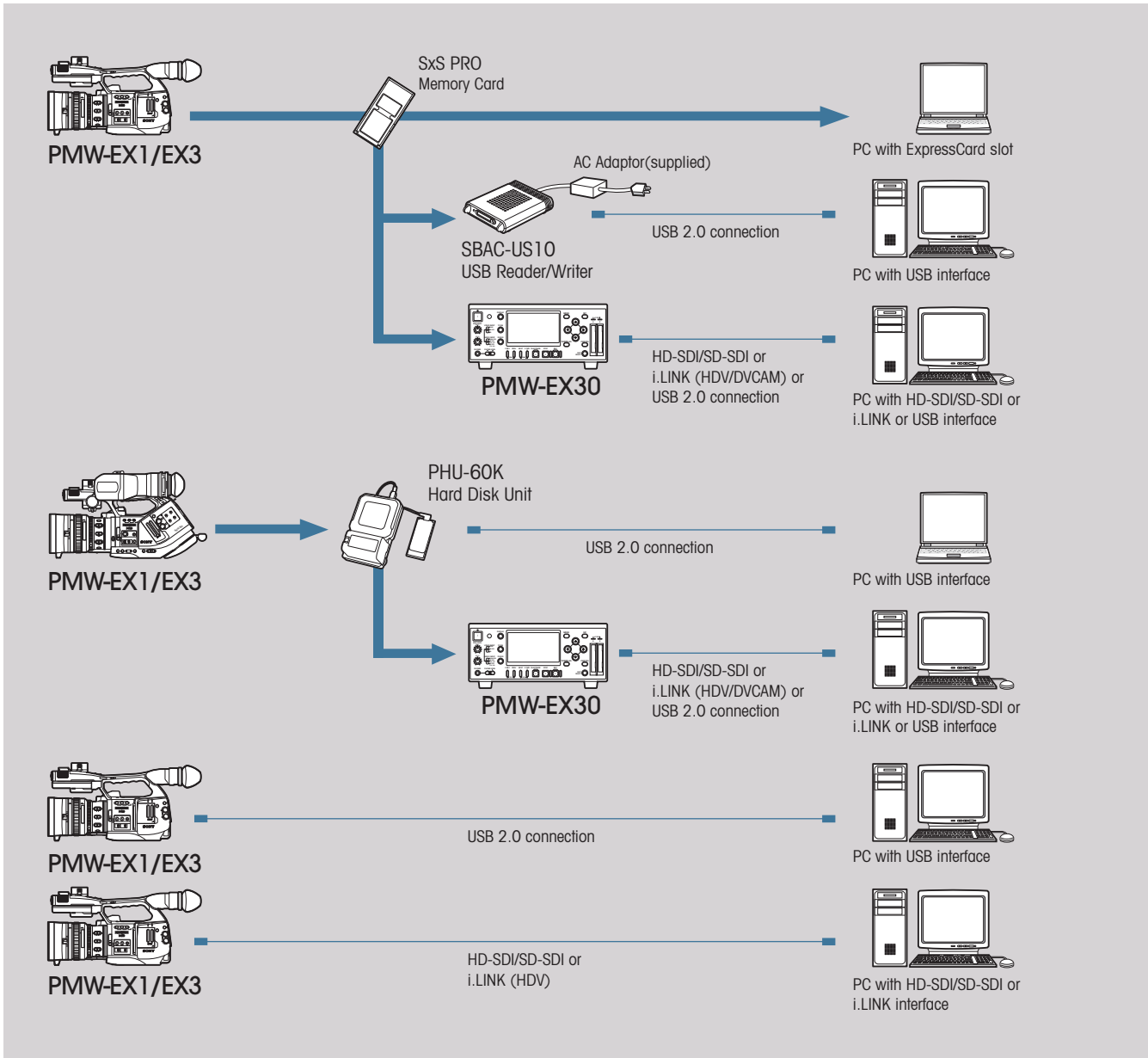

Viewing and Dubbing

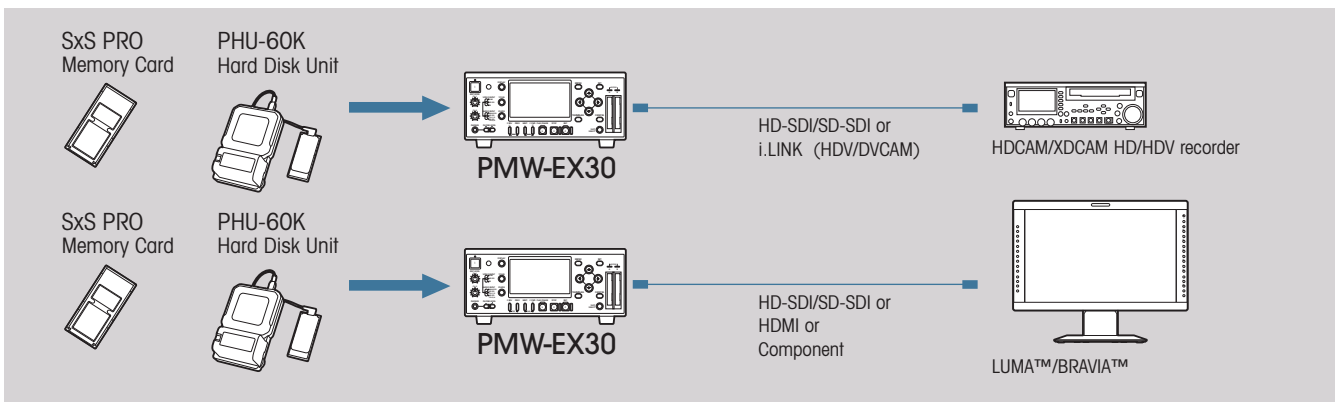

Archiving

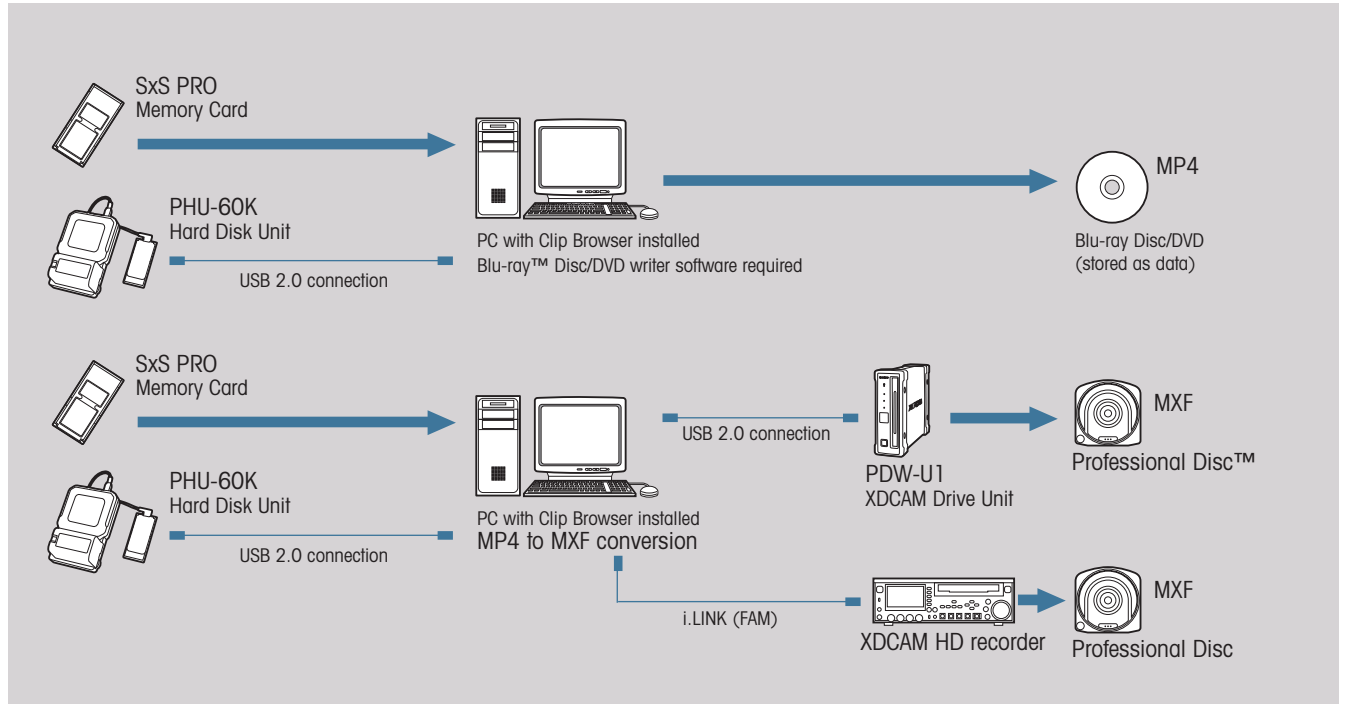

Live Event

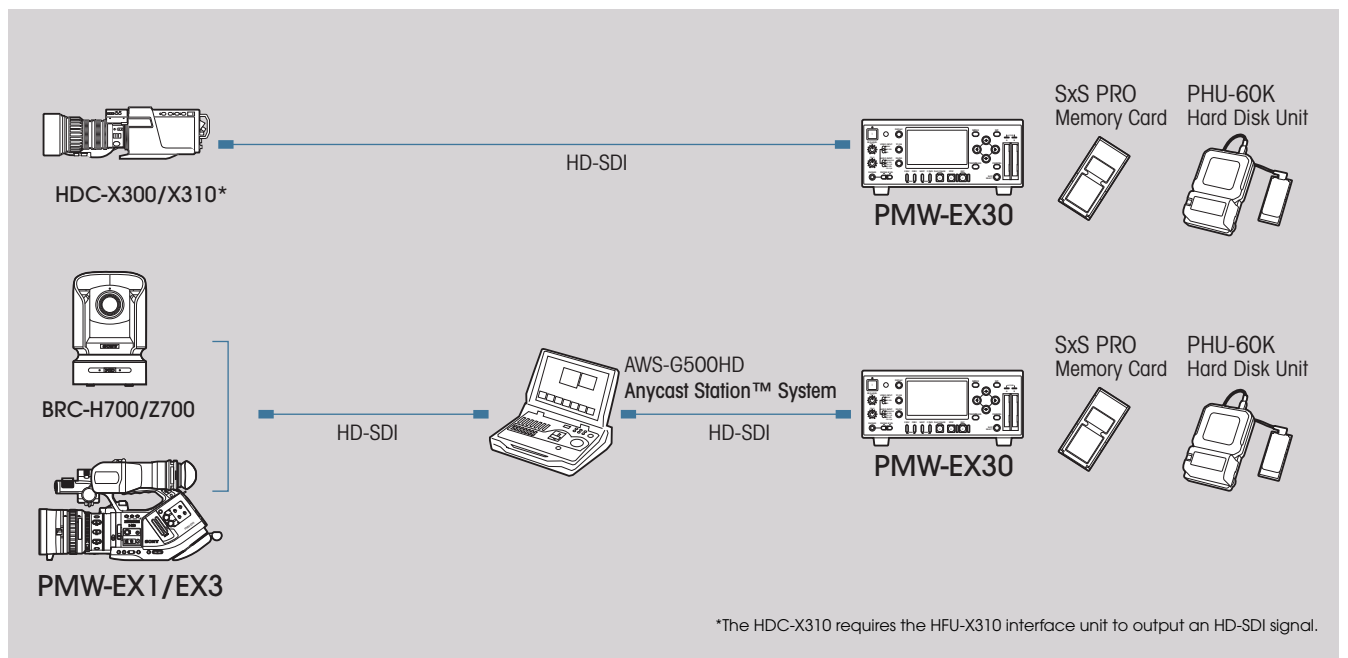

XDCAM EX Camcorder Specifications

		PMW-EX1	PMW-EX3
General			
Weight		Approx. 5 lb 4 oz (2.4 kg) (body) Approx. 6 lb 2 oz (2.8 kg) (with lens hood, large eye cup, BP-U30 battery, one SxS PRO memory card)	Approx. 4 lb 2 oz (1.9 kg) (without lens) Approx. 7 lb 9 oz (3.6 kg) (with lens, lens hood, eye piece, BP-U30 battery, one SxS PRO memory card)
Dimensions (W x H x D)		7 1/8 x 7 x 12 3/8 inches (178 x 176 x 311.5 mm) without projection	9 7/8 x 8 3/8 x 16 3/4 inches (250 x 210 x 425 mm) without projection
Power requirements		DC 12 V	
Power consumption		Approx. 12 W (while recording, EVF On, LCD monitor Off)	Approx. 13.5 W (while recording, LCD viewfinder On)
Operating temperature		+32 to +104 °F (0 to +40 °C)	
Storage temperature		-4 to +140 °F (-20 to +60 °C)	
Continuous operating time		Approx. 240 min. with BP-U60 battery Approx. 120 min. with BP-U30 battery	Approx. 210 min. with BP-U60 battery Approx. 100 min. with BP-U30 battery
Recording format	Video	MPEG-2 Long GOP HQ mode: VBR, maximum bit rate: 35 Mb/s, MPEG-2 MP@HL SP mode: CBR, 25 Mb/s, MPEG-2 MP@H14	
	Audio	Linear PCM (2ch, 16-bit, 48-kHz)	
Recording frame rate	NTSC setting	HQ mode: 1920 x 1080/59.94i, 29.97P, 23.98P, 1280 x 720/59.94P, 29.97P, 23.98P SP mode: 1440 x 1080/59.94i	
	PAL setting	HQ mode: 1920 x 1080/50i, 25P, 1280 x 720/50P, 25P SP mode: 1440 x 1080/50i	
Recording/Playback time	HQ mode	Approx. 100 min. with SBP-32 (32 GB) memory card** Approx. 50 min. with SBP-16 (16 GB) memory card Approx. 25 min. with SBP-8 (8 GB) memory card	
	SP mode	Approx. 140 min. with SBP-32 (32 GB) memory card** Approx. 70 min. with SBP-16 (16 GB) memory card Approx. 35 min. with SBP-8 (8 GB) memory card	
Lens			
Lens mount		—	1/2-inch EX mount
Zoom ratio selectable		14x (optical), servo/manual	
Focal length		f = 5.8 to 81.2 mm (equivalent to 31.4 to 439 mm on 35 mm lens)	
Iris		F1.9 to F16 and Close, auto/manual selectable	
Maximum relative aperture		1:1.9	
Focus		AF/MF/Full MF selectable, 800 mm to ∞ (MACRO OFF), 50 mm to ∞ (MACRO ON, Wide), 735 to ∞ (MACRO ON, Tele)	
Image stabilizer		ON/OFF selectable, shift lens	
Filter thread		M77 mm, pitch 0.75 mm (on lens)	
Camera			
Pickup device		3-chip 1/2-inch type Exmor Full HD CMOS	
Effective picture elements		1920 (H) x 1080 (V)	
Optical system		F1.6 prism system	
Built-in filters	ND filter	OFF: Clear, 1: 1/8ND, 2: 1/64ND	
Sensitivity (2000 lx, 89.9% reflectance)		F10 (typical) (1920 x 1080/59.94i mode)	
Minimum illumination		0.14 lx (typical) (1920 x 1080/59.94i mode, F1.9, +18 dB gain, with 64-frame accumulation)	
S/N ratio		54 dB (Y) (typical)	
Horizontal resolution		1000 TV lines or more (1920 x 1080i mode)	
Shutter speed		1/32 to 1/2000 sec.	
Slow Shutter (SLS)		2-, 3-, 4-, 5-, 6-, 7-, 8-, 16-, 32-, and 64-frame accumulation	
Slow & Quick Motion function	720P	Selectable from 1 to 60 fps as recording frame rate	
	1080P	Selectable from 1 to 30 fps as recording frame rate	
Signal inputs/outputs			
Audio input		XLR-3-pin (female) (x 2), line/mic/mic +48 V selectable	
AV output		AV multi (x 1) Audio: -10 dBu (47 kΩ load, reference level) Analog composite/S-Video: NTSC or PAL	—
Composite output		—	BNC (x1), 1.0 Vp-p, 75 Ω
S-Video output		—	Y: 1.0 Vp-p, 75 Ω unbalanced, sync negative
Audio output		—	RCA type(CH-1,CH-2),-10 dBu (reference level), 47 kΩ
Component output		Mini D (x 1) Y: 1.0 Vp-p, 75 Ω, Pb/Pr: 0.7 Vp-p, 75 Ω	
SDI output		BNC (x 1), HD-SDI/SD-SDI selectable	
i.LINK input/output		IEEE1394, 4-pin (x 1), HDV stream input/output, S400	
Timecode input		—	BNC (x1), 0.5 to 1.8 Vp-p, 10 Ω
Timecode output		—	BNC (x1), 1.0 Vp-p, 75 Ω
Genlock input		—	BNC (x1), 1.0 Vp-p, 75 Ω
USB		Mini-B (x 1), USB 2.0 High-speed	
Headphone output		Stereo mini-jack (x 1), -20.5 dBu (reference level output, 16 Ω load)	
Speaker output		Monaural, 250 mW	
DC input		DC jack	
Battery input		5-pin	
Remote		—	8-pin

Built-in viewfinder		
LCD viewfinder/screen	3.5-inch* type color LCD monitor, approx. 921000 effective pixels, 640 (H) x 3 (RGB) x 480 (V), 16:9, hybrid type	
	0.54-inch* type color LCD, 1120 (H) x 225 (V), 16:9	—
Built-in microphone		
Capsule type	Omni-directional stereo electret condenser microphone.	
Media slot		
Type	ExpressCard/34 (x 2)	
Interface	ExpressCard compatible	
Supplied accessories		
	Lens hood (x 1), large eye cup (x 1), IR Remote Commander unit (x 1), USB cable (x 1), AV connecting cable (x 1), component video cable (x 1), shoulder strap (x 1), operation manual (x 1), XDCAM EX Clip Browsing software (x 1), SxS device driver software (x 1), BP-U30 battery (x 1), BC-U1 charger (x 1)	14x zoom lens (x 1), Lens hood (x 1), LO-3830 1/2-inch lens adaptor (x 1), IR Remote Commander unit (x 1), USB cable (x 1), component video cable (x 1), shoulder strap (x 1), operation manual (x 1), Cheek Pad, XDCAM EX Clip Browsing software (x 1), SxS device driver software (x 1), BP-U30 battery (x 1), BC-U1 charger (x 1)

*Viewable area measured diagonally.

**Early PMW-EX1 camcorders require an upgrade to use the 32-GB memory card.

XDCAM EX Deck Specifications

PMW-EX30		
General		
Weight	Approx. 4 lb 6 oz (2.0 kg) (body) Approx. 5 lb 4 oz (2.4 kg) with AC adaptor and stand	
Dimensions (W x H x D)	Approx. 8 3/8 x 3 1/2 x 7 7/8 inches (210 x 88 x 200 mm)	
Power requirements	DC 12 V	
Power consumption	Approx. 12 W	
Operating temperature	+32 to +104 °F (5 to +40 °C)	
Storage temperature	-4 to +140 °F (-20 to +60 °C)	
Recording format	Video	MPEG-2 Long GOP HQ mode: VBR, maximum bit rate: 35 Mb/s, MPEG-2 MP@HL SP mode: CBR, 25 Mb/s, MPEG-2 MP@H14
	Audio	Linear PCM (2ch, 16-bit, 48-kHz)
Recording frame rate	NTSC setting	HQ mode: 1920 x 1080/59.94i, 29.97P*, 23.98P*, 1280 x 720/59.94P SP mode: 1440 x 1080/59.94i
	PAL setting	HQ mode: 1920 x 1080/50i, 25P*, 1280 x 720/50P SP mode: 1440 x 1080/50i
Recording/Playback time	HQ mode	Approx. 100 min. with SBP-32 (32 GB) memory card Approx. 50 min. with SBP-16 (16 GB) memory card Approx. 25 min. with SBP-8 (8 GB) memory card
	SP mode	Approx. 140 min. with SBP-32 (32 GB) memory card Approx. 70 min. with SBP-16 (16 GB) memory card Approx. 35 min. with SBP-8 (8 GB) memory card
Signal inputs/outputs		
Composite output	BNC(x1), 1.0 Vp-p, 75 Ω unbalanced	
S-Video output	Y: 1.0 Vp-p, 75 Ω unbalanced, sync negative	
Component output	BNC (x 3), Y: 1.0 Vp-p, 75 Ω, Pb/Pr: 0.7 Vp-p, 75 Ω	
Audio input	RCA type (CH-1, CH-2)	
Audio output	RCA type (CH-1, CH-2), -10 dBu (reference level), 47 kΩ	
HD-SDI input	BNC (x 1)	
SDI output	BNC (x 1), HD-SDI/SD-SDI selectable	
HDMI output	Type A 19-pin (x 1)	
i.LINK input/output	IEEE1394, 6pin (x 1), HDV stream input/output, DVCAM stream output, S400	
USB	Mini-B (x 1), USB 2.0 High-speed	
Headphone output	Stereo mini-jack (x 1), 16 Ω, 30 mW	
DC input	DC jack	
LCD panel		
LCD panel	3.5-inch** type color LCD monitor, approx. 921000 effective pixels, 640 (H) x 3 (RGB) x 480 (V), 16:9, hybrid type	
Media slot		
Type	ExpressCard/34 (x 2)	
Interface	ExpressCard compatible	
Supplied accessories		
	AC Adaptor (x 1), IR Remote Commander unit (x 1), USB cable (x 1), Stand (x 2), operation manual (x 1), XDCAM EX Clip Browsing software (x 1), SxS device driver software (x 1)	

*Early PMW-EX30 requires an upgrade to achieve these capabilities.

**Viewable area measured diagonally.

SONY

Sony Electronics Inc.
1 Sony Drive
Park Ridge, NJ 07656
click: sony.com/xdcamex

V-2416-C (MK10481V2)

© 2008 Sony Electronics Inc. All rights reserved.
Reproduction in whole or in part without written permissions is prohibited.
Features, design and specifications are subject to change without notice.
All non-metric weights and measurements are approximate.
PSP is a trademark of Sony Computer Entertainment, Inc.
Sony, XDCAM EX, XDCAM, CineAlta, SxS PRO, SxS, Exmor, Picture Profile, Shot Transition, Remote Commander, i.LINK,
Professional Disc, HDCAM, LUMA, BRAVIA and DVCAM are trademarks of Sony.
HDV and HDV logo are trademarks of Sony Corporation and Victor Company of Japan, Limited (JVC).

Printed in USA (3/09)