

**SONY**<sup>®</sup>

Digital HD Video Camera Recorder

**HVR-V1U**



**HDV**<sup>™</sup>  
HDV 1080i

# Adding 1080-24p/30p Image Capture to the Sony HDV Family of Camcorders – the HVR-V1U HDV Camcorder

Since their sensational debut in 2004, Sony HDV™ products adopting the HDV 1080i specification have provided and continue to provide cost-effective HD program production. With high picture performance and superb functionality, they are trusted around the world for a wide range of HD applications.

In line with its commitment to the HDV format, Sony introduces the HVR-V1U – a stunning new model that extends the HDV line-up into the world of digital cinema and drama productions.

The HVR-V1U offers 24p and 30p progressive scanning, in addition to 60i interlaced. The images captured at 24p are recorded on tape at a 60i field rate through means of 2-3 pull-down. Using a compatible nonlinear editor\*<sup>1</sup>, this 2-3 sequence is recognized, allowing precise 24p editing of the HDV material. The 2-3 pull-down approach also allows the HVR-V1U to be easily integrated into existing HDV systems operating in 60i mode. In its compact, lightweight, and ergonomically designed chassis, the HVR-V1U camcorder integrates advanced technologies such as the newly developed 3 ClearVid CMOS Sensor imaging system – which is only made possible by Sony's industry-leading semiconductor technology – and a stunning optical 20x Carl Zeiss Vario-Sonnar T\*® zoom lens. Such features enable operators to capture vibrant, highly detailed HDV images with an extreme level of mobility, ease of use, and operational comfort suited for any shooting scenario. In addition to HDV 1080i recording and playback, the camcorder also offers DVCAM™/DV recording and playback capabilities, as well as digital down-conversion of recordings made in HDV 1080i. These bridges between HD and SD allow the camcorder to be used in any DV-compatible system, whether it uses the HDV, DVCAM, or DV format.

And for even greater power, the optional HVR-DR60 Hard Disk Recording Unit – which is optimized for use on the HVR-V1U camcorder – streamlines the subsequent editing and archiving processes.

Adding this unit allows images captured by the camcorder to be simultaneously recorded to tape and hard disk. After a shoot is complete, simply connecting the HVR-DR60 to a compatible nonlinear editing system provides quick access to files from the editing software and completely eliminates the time-consuming digitizing process. With a maximum recording time of 4.5 hours on the HVR-DR60, this hybrid tape and hard disk recording system offers a multitude of benefits for shooting, editing, and archiving SD and HD material. Available at a price comparable to Sony DVCAM handheld camcorders, the HVR-V1U offers new creative shooting opportunities to both the HD and SD worlds.

\*<sup>1</sup> Please contact your nearest Sony office or authorized dealer for information on compatible nonlinear editors.





# HDV

HDV 1080i



From the outset, the HDV 1080i specification of the HDV\*<sup>2</sup> format was developed to record stunning HD images with 1080 active scanning lines on DV cassette tapes. It adopts the MPEG-2 compression format, using 8-bit digital component recording at approximately 25 Mb/s, which is the same data rate as the DVCAM/DV format, enabling a long recording time on compact DV cassettes.

For example, more than 60 minutes of high-quality HD images can be recorded on a mini DV cassette. As with the DVCAM and DV formats, the HDV format allows an i.LINK™ connection to compatible nonlinear editors, enabling a cost-effective

HD production system. The sheer volume of HDV 1080i professional and consumer equipment used around the world is a clear indication that HDV 1080i has become one of the most popular HD formats.

\*<sup>2</sup> Although not used in Sony HDV products, the HDV format also defines the HDV 720p specification, which features 720 effective scanning lines (progressive scanning system).

### Long Recording Time

The HVR-V1U uses mini cassette tapes and provides a maximum recording time of 63 minutes with the PHDVM-63DM.

## INNOVATIVE TECHNOLOGIES

### 3 ClearVid CMOS Sensor Imaging System

The ClearVid CMOS Sensor™ has been developed using the most advanced technologies in the semiconductor industry. Thanks to the unique grid arrangement of the photo diode sensors, in which each is rotated by 45 degrees, sensor resolution has been optimized and the photosensitive surface area has been maximized.

The HVR-V1U employs a 3-chip ClearVid CMOS Sensor imaging system, which produces high-resolution (1920 x 1080) images with rich and natural colors. The combined use of the 3 ClearVid CMOS Sensor imaging system and the Enhanced Imaging Processor™ technology has enabled a most precise interpolation scheme, which concludes within each R, G, and B channel. This allows a higher resolution for each R, G, and B channel than is offered by equivalent-class camcorders that resort to spatial offset techniques to improve resolution.

Unlike CCD sensors, there is no vertical smear in the ClearVid CMOS Sensor imaging system when shooting high-intensity subjects, further reducing shooting-condition constraints.

**3** ClearVid  
CMOS sensor

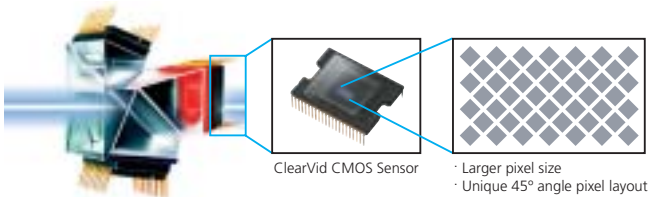

### Enhanced Imaging Processor (EIP) Technology

The EIP is a newly developed imaging processor that brings out the full power of the 3 ClearVid CMOS Sensor imaging system. It handles video data in 1920 x 1080p and 4:2:2 color space for high-quality signal processing before recording it to tape in the HDV format\*<sup>3</sup>. Combined use of the EIP and 3 ClearVid CMOS Sensor imaging system allows the HVR-V1U camcorder to provide extremely high image quality with a high level of gradation and detailed image reproduction.

\*<sup>3</sup> The HDV recording is in 1440 x 1080i and 4:2:0 color space.

### Carl Zeiss Vario-Sonnar T\* Lens

The HVR-V1U is equipped with a high-quality Carl Zeiss Vario-Sonnar T\* lens. Thanks to its multi-layer coating and extra-low dispersion glass, this lens offers excellent spectral characteristics, which result in virtually negligible chromatic aberrations.

### Optical 20x Lens and Optional 0.8x Wide Conversion Lens

The Vario-Sonnar T\* lens of the HVR-V1U features a 20x zoom function. Moreover, the built-in digital extender\*<sup>4</sup> increases the zoom ratio to approximately 30x. The optional VCL-HG0868K 0.8x wide conversion lens uses the bayonet mount system for instant attachment or detachment. Combining these lens features, operators can effortlessly capture close-up or wide-angle shots as their video production requires.

\*<sup>4</sup> The digital extender function is not available in progressive scan modes.

### Super SteadyShot System (Optical)

The HVR-V1U employs the Super SteadyShot™ system, which has sensors that detect horizontal and vertical movements independently. It uses a prism system located behind the lens to adjust and optically compensate for unsteady camera handling.



## Switchable Recording and Playback – HDV 1080i/DVCAM/DV

The HVR-V1U can switch between HDV 1080i, DVCAM, and DV\*5 recording, providing the full flexibility to record in either standard- or high-definition format according to different production needs.

\*5 The HVR-V1U supports DV SP mode only; DV LP mode is not available.

## Down-conversion Playback Capabilities

The HVR-V1U has a built-in down-conversion capability, allowing 1080i recordings to be output as 480i signals. The 480i signals can be output from the i.LINK\*6 connector. In addition, these signals can also be output from either the analog component, composite, or S-Video connectors. This allows 1080i recordings to be edited using nonlinear editing systems running DV editing software, and viewing the 1080i recording on an SD monitor.

When down-converting these signals, the aspect ratio displayed can be converted from 16:9 to 4:3. Display modes can be selected from Squeeze, Letterbox\*7, or Edge crop.\*8

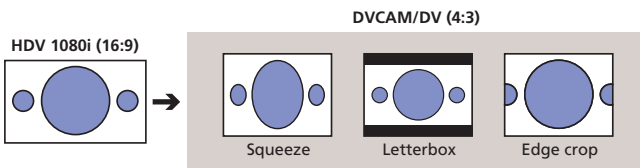

### Recording, Playback and Down-conversion Formats

Recording Format	Playback/Down Conversion Format	Output				
		i.LINK	Analog Component	HDMI	Analog Composite	S-Video
HDV1080i	1080/60i	○	○	○	—	—
	480/60i (SQ/EC)	○	△ 1	△ 2	△ 3	—
	480/60i (LB)	—	△ 1	△ 2	△ 3	—
DVCAM/DV (480/60i)	480/60i	○	△ 1	△ 2	△ 3	—

○ : Available  
 △ : Either △1 or △2 or △3 connection is available. When cables are connected to these outputs, the △ connection with a smaller number has priority.  
 SQ=Squeeze, EC=Edge Crop, LB=Letter Box

\*6 i.LINK is a trademark of Sony used only to designate that a product contains an IEEE 1394 connector. Not all products with an i.LINK connector will necessarily communicate with each other. For information on compatibility, operating conditions, and proper connection, please refer to the documentation supplied with any device with an i.LINK connector. For information on devices that include an i.LINK connection, please contact your nearest Sony office.

\*7 Letterbox mode is not available from the i.LINK connector.

\*8 Edge crop mode from the i.LINK connector will be available by a firmware upgrade. For details, please contact your nearest Sony office or authorized dealer.

## 16:9 Widescreen Acquisition in DVCAM and DV Formats

When recording in DVCAM and DV formats, standard-definition images can be captured by the HVR-V1U in either 16:9 or 4:3 aspect ratio.

## 2-channel XLR Audio Input

The HVR-V1U has two XLR audio input connectors for connecting professional microphones or for receiving external-line audio sources. Microphone power of approximately 48 V can be supplied for the external condenser microphone. INPUT 1 audio can be recorded either on CH1 only or on both CH1 and CH2 audio tracks.



## Time Code Preset

The HVR-V1U's time code can be manually preset using any number in H/M/S/F (hours/minutes/seconds/frames) to record desired tape-position information. The time code mode can be selected between "REC RUN" and "FREE RUN". In addition to time code, user bits can also be set and recorded.

## Interval Recording

Interval recording is a unique function that records signals at pre-determined intervals (longer than 30 seconds) for pre-determined durations (longer than 0.5 seconds). This is ideal for recording subjects over long periods, such as the movement of clouds or the blossoming of flowers.

## Smooth Slow Rec

The Smooth Slow Rec\*<sup>9</sup> function enables clean slow-motion playback by capturing images at four times faster than the normal field rate (240 fields/s). For example, when setting the function to Fine mode, quad-speed images are captured for three seconds, stored in the built-in buffer memory, and then recorded to tape (in either HDV, DVCAM, or DV format) as slow-motion pictures lasting 12 seconds. The Smooth Slow Rec function also supports Standard and Low modes, which can record high-speed images for 6 and 12 seconds, respectively.

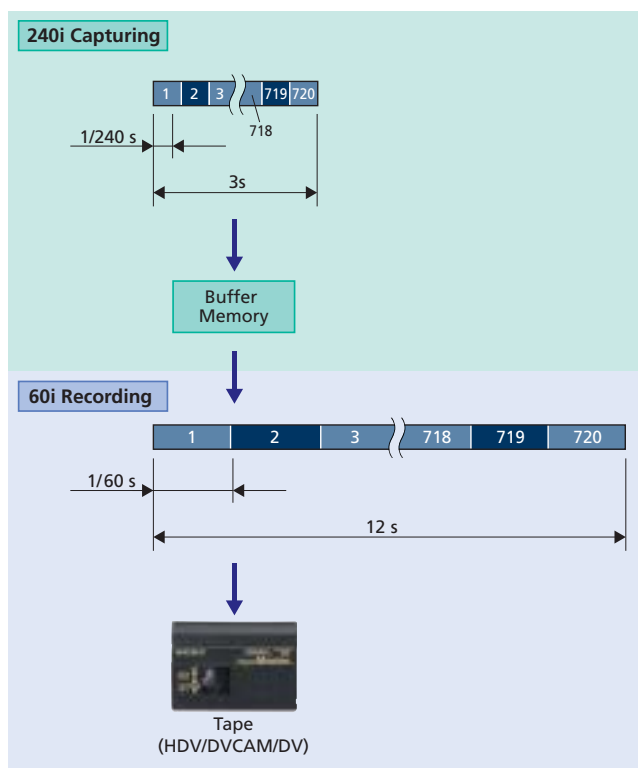

\*<sup>9</sup> When using the Smooth Slow Rec function, the resolution of the camera image decreases. For example, the resolution at Fine mode is 640 x 360 pixels. Also, audio recording is not available.

## Shot Transition Function

The Shot Transition™ function allows for smooth automatic scene transitions. After an operator has programmed a shot's start and end settings (e.g., for zoom, focus, iris, gain, shutter speed, and white balance) and pressed the start button, a smooth transition takes place over the duration of the shot by automatically calculating intermediate setting values. This is very useful when complex camera settings are required during the scene transition – for example, when panning the camcorder from a distant subject to a close subject.

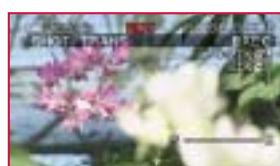

Shot A

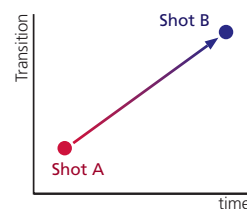

### LINEAR

Makes a linear transition.

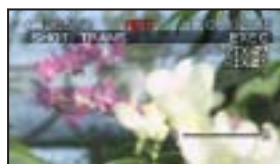

Shot B

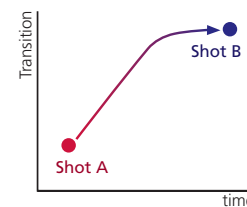

### SOFT STOP

Makes the transition slow at the end.

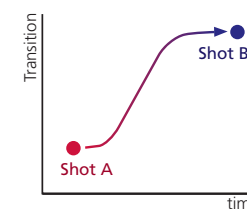

### SOFT TRANSITION

Makes the transition slow at the beginning and end, and linearly in between.

## Picture Profile™ Feature

Up to six different picture-tonal settings can be saved in the memory with custom 12-character names as picture profiles on the HVR-V1U and displayed on the LCD monitor at the touch of a button. This allows operators to easily call up customized picture-tonal settings to suit particular shooting conditions, rather than having to readjust the camera each time. The factory default setting includes six pre-loaded picture profiles for typical shooting conditions.

## Last Scene Review

At the touch of a button, the video and audio of the last shot taken by the HVR-V1U can be instantly played back on the LCD monitor. This is achieved without even having to switch from "Camera mode" to "VTR mode". After playback, the tape is automatically cued up to the end of the last shot to continue back space editing. These features allow operators to seamlessly shoot and review material.

## Playback Zoom

Using the playback zoom function of the HVR-V1U, a selected area of the recorded HD images can be enlarged and played back on the LCD monitor and viewfinder, allowing operators to perform a detailed evaluation of the material. These enlarged images can also be output in SD format via the i.LINK and analog connectors, allowing operators to cut out parts of the HD image and use them as SD material.

## TC LINK Function for Multi-camera Operations

Using the TC LINK function, the time code of the HVR-V1U can be synchronized with another camcorder such as the HVR-Z1U, DSR-PD170, or a second HVR-V1U. By connecting the HVR-V1U to another i.LINK compatible camcorder via an i.LINK cable and activating this function, the HVR-V1U's time code generator will switch to free-run mode and reset its time code to that provided from the connected camcorder. Once the time code of the HVR-V1U is synchronized\*<sup>10</sup>, the i.LINK cable can be disconnected, and the next HVR-V1U that needs synchronized time code can be set up.

TC LINK is a convenient function when using the HVR-V1U in multi-camera operations, such as live-event recording and stage-shooting applications.

\*<sup>10</sup> The synchronization accuracy is within one frame.

## Long Operating Time

With the optional NP-F970 InfoLiTHIUM™ Rechargeable Battery Pack attached, the HVR-V1U can operate continuously for up to 7 hours.

### Battery Life

Continuous Recording Time*	With LCD** Viewfinder On		With LCD** Monitor On		With LCD** Viewfinder and Monitor On	
	HDV	DVCAM/DV	HDV	DVCAM/DV	HDV	DVCAM/DV
NP-F570 (supplied)	135 min	135 min	135 min	135 min	130 min	130 min
NP-F770 (optional)	280 min	290 min	280 min	290 min	265 min	275 min
NP-F970 (optional)	415 min	430 min	415 min	430 min	395 min	410 min

\* Continuous recording time, indoors at 25°C.

\*\*With the LCD backlight on



## OPERATIONAL CONVENIENCE

### Compact and Lightweight Design

The HVR-V1U is designed to be very compact and lightweight, for a high level of mobility in the field. It weighs approximately 1.5 kg (3 lb 6 oz) (camcorder only).

### Ergonomic Design

The design of the HVR-V1U is based on years of Sony experience in camera ergonomics, and provides ease of use and operational comfort.

### Audio Level Dials

Two audio level dials are located on the carrying handle where they are easy to adjust, while avoiding inadvertent operation. The microphone power can be easily turned on and off via the mechanical switches.

### Zoom Ring and Focus Ring

The motorized zoom ring and focus rings provide a smooth and natural operational feel for fine adjustments of zoom and focus settings.

### EXPOSURE/IRIS Dial

The EXPOSURE/IRIS dial is located near the zoom and focus rings for convenient camera operations. The dial can be used to set the iris, AE shift, and exposure compensation functions, giving operators manual exposure control during auto exposure mode. The rotation direction and response for controlling these functions can be selected via the menu according to operators' preference.

### One-push AF Button

The one-push auto focus button, which is used for temporary auto focus adjustments, is located near the EXPOSURE/IRIS dial and the zoom and focus rings.

### Carrying Handle

A rubber coating is used on the bottom of the handle for slip resistance. A large space of 34.3 mm (1 3/8 inches) is offered below the handle for secure carrying of the camcorder, even when wearing gloves.

### On-handle Zoom Lever and Rec Start/Stop Button

In order to facilitate zoom control and recording operations during low-angle shooting, an additional zoom lever and a rec start/stop button are available on the carrying handle.



### Camera Setting Storage on Memory Stick Duo Media

The HVR-V1U provides a convenient function to store camera setting data. It can store and recall 20 different setting configurations using Memory Stick Duo™ media, and a further two using its built-in memory. This is useful for sharing the same setting configurations among multiple cameras.



## Side Grip

The side grip is located near the camcorder's center of gravity. By tilting it to the front by approximately 10 degrees, it lightens the load on the operator's wrist during shooting.

## Color Viewfinder with Large-size Eye Cup

The HVR-V1U is equipped with a high-resolution color LCD viewfinder of approximately 211,000 pixels in a widescreen aspect ratio of 16:9. Operators can choose to display pictures in color or in black and white. In addition to a standard-size eye cup, a large-size eye cup is also supplied. This can be attached to the standard-size eye cup to provide superb light-blocking capability, easy focusing, and more comfortable use of the viewfinder.



## 3.5-inch Type Widescreen, Clear Photo LCD plus™ Monitor

The HVR-V1U is equipped with a 3.5-inch\*<sup>11</sup> type widescreen color LCD monitor, which provides enhanced brightness and a high level of color reproduction.

\*<sup>11</sup> Viewable area, measured diagonally.



With the Optional SH-L35WBP LCD Hood

## Marker

When shooting in 16:9 aspect ratio mode, markers such as 4:3, 13:9, 14:9, and 15:9 can be displayed on the HVR-V1U's LCD monitor and viewfinder, allowing scenes to be captured to match the aspect ratio of the edited master.

## Six Assign Buttons

Functions frequently used in the field can be assigned to six Assign Buttons (push buttons), allowing operators to make rapid changes depending on the shooting conditions.

The assignable functions include: Last Scene Review, Marker, Hyper Gain, Digital Extender, All Scan Mode, Spot Light, Focus Infinity, Rec Review, End Search, Index, Peaking, SteadyShot, Color Bar, Back Light, Fader, Display, and Picture Profile.

## Manual/Auto Setting Switches

Iris, gain, shutter speed, white balance, and menu buttons are located on the left side of the rear panel to avoid them being accidentally pressed during operation.

## Video Connectors

Video connectors such as i.LINK, analog component output, and multi-AV output connectors are located on the right side of the rear panel where they do not get in the way of camera operations during shooting.

## HDMI (High-Definition Multimedia Interface) Output Connector

The HDMI output connector transfers non-compressed, high-definition digital video and audio signals to other HDMI-equipped devices, such as consumer HDTV monitors, via a single cable.

Headphone Connector



## Progressive Shooting Capability Including 24p with 2-3 Pull-down and 30p

Thanks to the 3 ClearVid CMOS Sensor imaging system and Enhanced Imaging Processor (EIP) technology, the HVR-V1U supports 24p (23.978 fps)\*<sup>12</sup>, the frame rate of film and 30p (29.97 fps) progressive scan modes, in addition to typical 60i. The signals generated by the 3 ClearVid CMOS Sensor imaging system are processed in the progressive domain as 1920 x 1080p signals, allowing high-resolution progressive footage to be captured.

The 24p progressive scan signals are recorded to tape as 60i signals through means of 2-3 pull-down. This 2-3 sequence HDV material can be reverted to its original 24p form, as captured by the camera, using a compatible nonlinear editor\*<sup>13</sup>. Similarly, a 30p signal is recorded as a 60i signal by dividing each frame into two fields. This approach allows 24p and 30p progressive footage to be played back or fed to an editing suite using any of the thousands of Sony HDV solutions already in use throughout the world.

### 24p Mode (2-3 Pull-down)

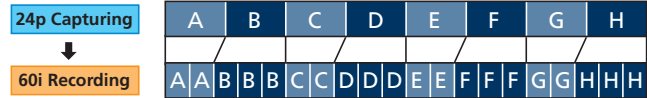

### 30p Mode

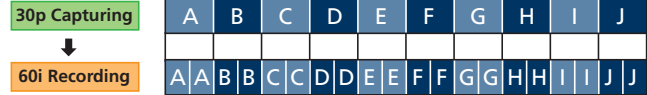

\*<sup>12</sup> The 24p (progressive scan) images captured with the HVR-V1U are recorded using a method that allows them to be viewed on existing Sony HDV (60i) devices. Two recording modes can be selected depending on your editing requirements.

The "24A" mode should be selected when the material is intended for 24p progressive editing - such as for film productions - using a nonlinear editor compatible with this mode. Interruptions in time code and video may appear between recordings when viewed on an HDV device. These interruptions do not occur after the recording is copied to an i.LINK compatible nonlinear editor system via the i.LINK connection, and the recordings can be correctly edited as normal 24p video clips. Recordings made in this mode can also be edited as typical 60i material.

The "24" mode should be selected when a 24p (motion) look is desired on 60i material, such as for TV program content. In this case, there are no interruptions in the time code or video between recordings. Recordings made in this mode can be edited as typical 60i material.

\*<sup>13</sup> Please contact your nearest Sony office or authorized dealer for information on compatible nonlinear editors.



## A Variety of Gamma Settings

The HVR-V1U offers a choice of various gamma setting functions, which makes it ideal for use in creative productions such as cinema films and drama programs.

### ■ Cinematone Gamma Feature

The HVR-V1U provides a special gamma feature – Cinematone Gamma™ – which allows operators to quickly set up and load a gamma curve with similar contrast characteristics to a film gamma curve. Three gamma curves can be selected from “OFF” (normal gamma), “TYPE1”, or “TYPE2”.

#### Gamma Characteristics

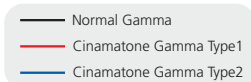
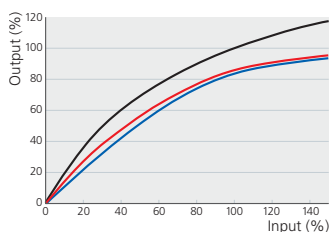

### ■ Black Stretch and Black Compress

**Black Stretch:** Enhances the video signal levels in dark picture areas for clear reproduction of dark contrast, without sacrificing highlight contrast of the same picture.

**Black Compress:** Suppresses video signal levels in dark picture areas to emphasize the depth of dark picture tones.

### ■ Knee Correction

The knee correction function compresses the wide dynamic range acquired by the CMOS sensors into the standard video-level range. The knee point is the video level from which the signal is compressed. By changing the knee point, the image contrast above the knee point can be changed. The HVR-V1U can select knee points from high, middle, low, and auto modes to meet various production needs.

## Cinematone Color Function

The Cinematone Color™ function of the HVR-V1U has been developed based on a thorough analysis of the color tone of cinema film, and the voices of colorists engaged in digital cinema productions.

The Cinematone Color function provides cinematic color for deep-color and high-contrast images approaching cinema film. In combined use with the Cinematone Gamma function, more cinema-quality images can be captured.



## Easy Operation for Cinematographers

The HVR-V1U can display setting values in a format that film camera operators are familiar with.

### ■ Focal Length Display in Meters or Feet

The focal length can be displayed on the LCD monitor and viewfinder in either feet (ft) or meters (m).

### ■ Shutter Speed Display in Units of Rotation Angles

Shutter speeds can also be displayed on the LCD monitor and viewfinder in units of rotation angles converted from shutter speeds.

## OTHER CONVENIENT FUNCTIONS

Still Picture Recording to Memory Stick Duo Media, 2-channel Independent Audio Level Control with Audio Level Meter on LCD Monitor, Simultaneous Operation of LCD Monitor and Viewfinder, AE Shift, Hyper Gain, All Scan Mode, AF Assist, Expanded Focus, Peaking, Status Check, Battery Info, Histogram Indicator, Zebra Patterns (100% to 70%)

## HVR-DR60 HARD DISK RECORDING UNIT

Mountable on Sony HDV and DVCAM camcorders, the HVR-DR60 Hard Disk Recording Unit can streamline the entire production process.



### Long Recording Time of 4.5 Hours

Via its i.LINK connection, the HVR-DR60 Hard Disk Recording Unit developed by Sony allows recording of HDV 1080i signals from a compatible HDV camcorder, or DV signals from a compatible DVCAM camcorder. The internal 1.8-inch hard disk drive (HDD) offers a large capacity of 60 GB, which translates into a long recording time of 4.5 hours (270 minutes) for both formats.

HDV 1080i signals are recorded as native HDV files (.m2t)\*<sup>14</sup>, while DVCAM or DV signals are recorded as DV-AVI (type1)\*<sup>14</sup> or RAW-DV\*<sup>14</sup> files.

HDV Files Stored on the HVR-DR60 Displayed on a PC Monitor



\*<sup>14</sup> During playback, interruptions in video may appear between recordings. These interruptions do not occur after the recordings are copied to an i.LINK compatible nonlinear editor system via the i.LINK connection, and the recordings can be correctly edited. For information on compatible nonlinear editors, please contact your nearest Sony office or authorized dealer.

### Hybrid Operation for Reliable Recording and Archiving

The HVR-DR60 offers a hybrid recording function, in which video and audio material is recorded simultaneously to the hard disk and tape, limiting the possibility that important shots could get lost or accidentally deleted. This hybrid function also facilitates instant archiving of source footage – which in many cases does not allow for retakes. After a shoot, operators can immediately archive the source tape and use the HVR-DR60 material as work footage. This saves the time and effort required to copy the original data to a separate high-capacity medium.

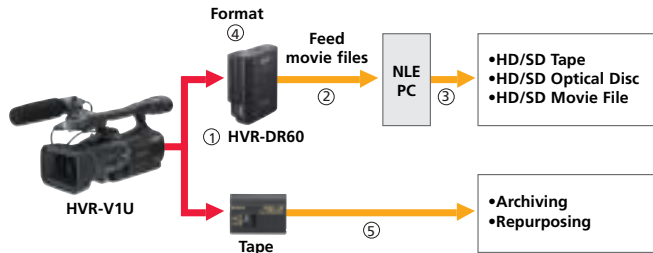

- ① Simultaneous recording
- ② Feed movie files
- ③ Edit the files
- ④ Format HVR-DR60 for next shoot
- ⑤ Archive recorded tape for repurposing



## Direct File Access from a Computer

When connected to a computer via an i.LINK connection, the HVR-DR60 is recognized by the computer as a standard external drive, and its recorded footage can be accessed directly like any normal video file. This saves the time previously required for digitizing material from the tape to a computer. Furthermore, video files stored on the HVR-DR60 can be transferred to a computer running compatible nonlinear editing software at a high speed of approximately 80 Mb/s (around three times faster than real time), which drastically reduces the time needed to copy source material to the editor's local drive.

These features allow operators to focus on more creative and productive editing tasks.



## Ideal Companion for the HVR-V1U

The HVR-DR60 can be used with existing HDV/DVCAM camcorders equipped with an i.LINK interface such as the HVR-Z1U and DSR-PD170. However, when used with the HVR-V1U, it offers some additional features only available in this combination.

### ■ Checking the Operational Status on the HVR-V1U

On the LCD monitor and viewfinder of the HVR-V1U, the operational status of the HVR-DR60 – such as connection, recording format, battery level, remaining recording time, recording folder name, etc. – can be checked. This keeps operators informed of both the camcorder and hard drive status, without taking their eyes away from what is being shot.



*HVR-DR60 Status Check*

### ■ Tapeless Recording

To trigger recording of the HVR-DR60, most HDV camcorders require a tape to be loaded. However, this is not the case with the HVR-V1U. The HVR-V1U sends the same rec start/stop trigger that controls its tape transport to the HVR-DR60. This feature offers operators the choice of tapeless operation or hybrid operation.

## HDD Smart Protection – Robust Recording and Shock Resistance

Three advanced technologies are used in the HVR-DR60 to provide reliable recording performance:

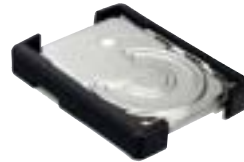

*Shock Absorbers*

1) Rubber shock absorbers hold the HDD unit in place, helping to prevent external shock from being transmitted when the HVR-DR60 chassis is subject to impact.

2) A 3G sensor detects gravitational acceleration in three dimensions, so however the HVR-DR60 may be oriented, the sensor can detect if it has been dropped. Should this occur, power to the HDD is shut off and the recording heads are retracted from the disk platter, pausing read/write operations.



*3G Sensor*

This helps protect the HDD from being damaged when the unit is accidentally dropped and subject to strong impact.

3) A buffer memory can store approximately 14 seconds of video and audio footage. Recordings are made by first writing the data to the buffer, and then writing the buffer data to the disk platter. Consequently, if the 3G sensor temporarily interrupts disk writes, video footage is not lost.

Thanks to such advanced technologies, the HVR-DR60 should continue to record stably even when dropped from as high as 100 cm (39 3/8 inches) (based on Sony's testing).

## Long Operating Hours Using Common Camcorder Batteries

The HVR-DR60 uses the same InoLITHIUM L Series batteries as the HVR-V1U, HVR-Z1U, and DSR-PD170 camcorders. With the smallest capacity NP-F570 battery, the HVR-DR60 can run continuously for up to 5.5 hours (330 min), and with the largest capacity NP-F970, this increases to up to 18 hours (1080 min). Long operating hours are offered using such camcorder batteries that HDV operators already have at hand.

## Compact and Perfect Balance

The HVR-DR60 measures just 81 x 45 x 100 mm (3 1/4 x 1 3/4 x 4 inches) in size and only about 230 g (8 oz) in weight. It can be mounted on a camcorder's cold shoe using the supplied shoe adapter, or attached using an optional VCT-1BP Bracket.

# SYSTEM DIAGRAM

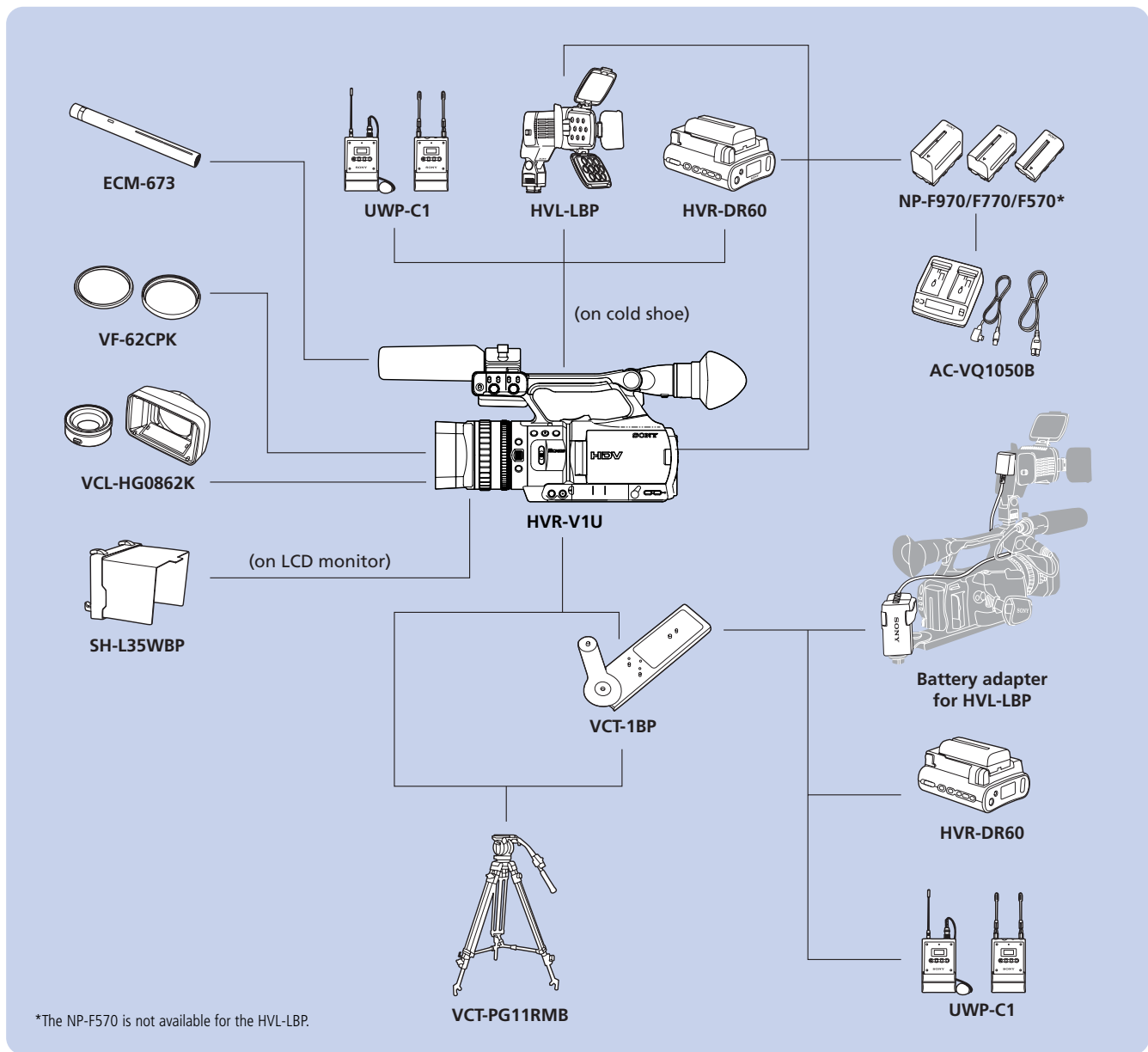

# DIMENSIONS

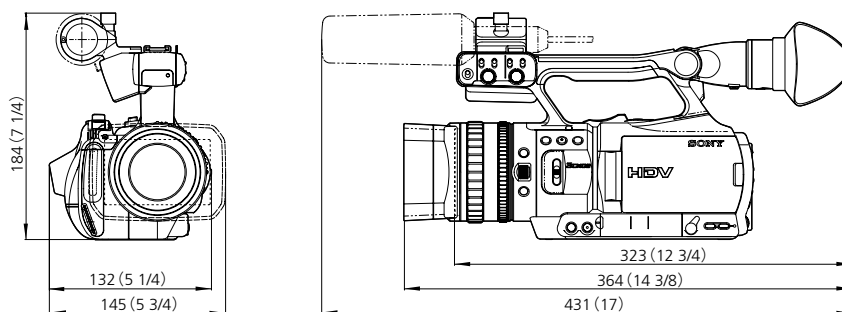

Unit: mm (inches)

## ACCESSORIES

A range of accessories for the HVR-V1U broadens shooting opportunities.



**VCL-HG0862K**  
0.8x Wide Conversion Lens

- Bayonet mount for easy attachment and detachment
- Lens hood supplied
- $\phi 86$  mm filter available without attaching the lens hood



**HVL-LBP**  
LED Light

- Brightness of 600 lx (1 m), life of approx. 10,000 hours (whole unit), and power consumption of 16 W
- Ideal for wide-angle shooting
- Uniform lighting over the entire projected area
- Spotlight projection with supplied condensing lens attached
- Light diffuser attached to soften shadows and reduce contrast
- Compatible with HVR-V1U batteries, such as the NP-F770/F970
- Long operating time: approximately 3 hours with the NP-F970 (at maximum brightness)



**2NP-F970**  
InfoLITHIUM Rechargeable Battery Pack



**NP-F570/F770/F970**  
InfoLITHIUM Rechargeable Battery Pack



**VF-62CPK PL**  
Filter Kit ( $\phi 62$  mm)



**RM-1BP**  
LANC Remote Controller



**VCT-PG11RMB**  
Video Tripod with RM-1BP Remote Control



**SH-L35WBP**  
LCD Hood



**VCT-1BP**  
bracket



**LCS-G1BP**  
Soft Carrying Case



**LCH-FXA**  
Hard Carrying Case



**PHDVM-63DM**  
DigitalMaster™ Mini Cassette Tape



**UWP-C1**  
UHF Synthesized Wireless Microphone Package



**ECM-673**  
Electret Condenser Microphone



**AC-VQ1050B**  
Battery Charger

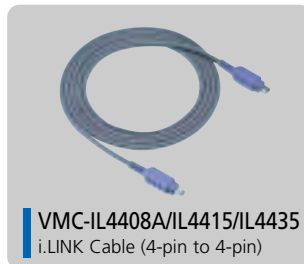

**VMC-IL4408A/IL4415/IL4435**  
i.LINK Cable (4-pin to 4-pin)



**VMC-IL4615/IL4635**  
i.LINK Cable (4-pin to 6-pin)



**DLC-HM15/HM30/HM50**  
HDMI Cable (1.5/3/5 m)

# SPECIFICATIONS

Camera section		
Lens		Carl Zeiss Vario-Sonnar T* zoom lens, 20x (optical), f = 3.9 to 78 mm, f = 37.4 to 748 mm* at 16:9 mode f = 45.7 to 914 mm* at 4:3 mode, F = 1.6 to 2.8, filter diameter: 62 mm
Built-in filter		1/4 ND, 1/16 ND
Focus		Auto, manual (focus ring/one push auto/infinity)
Imaging system		1/4-inch type, 3 ClearVid CMOS Sensor system
Picture elements		Approx. 1,037,000 pixels (effective), approx. 1,120,000 pixels (total)
White balance		Auto, one-push auto (2 positions), indoor (3200 K), outdoor (5800 K +15steps)
Manual shutter speed	60i/30p mode	1/4, 1/8, 1/15, 1/30, 1/60, 1/90, 1/100, 1/125, 1/180, 1/250, 1/350, 1/500, 1/725, 1/1000, 1/1500, 1/2000, 1/3000, 1/4000, 1/6000, 1/10000 s
	24p mode	1/3, 1/6, 1/12, 1/24, 1/40, 1/48, 1/50, 1/60, 1/96, 1/100, 1/120, 1/144, 1/192, 1/200, 1/288, 1/400, 1/576, 1/1200, 1/2400, 1/4800, 1/10000 s
Exposure		Auto, manual (Type1/Type2)
Gain		0, 3, 6, 9, 12, 15, 18 dB
Minimum illumination		4 lx with F1.6 at 18 dB
VTR section		
Recording format		1080/60i, 480/60i (NTSC)
Play out/Down conversion format		1080/60i, 480/60i (NTSC)
Tape speed	HDV/DV SP	Max. 18.812 mm/s
	DVCAM	Max. 28.218 mm/s
Playback/Recording time	HDV/DV SP	Max. 63 min with PHDVM-63DM cassette
	DVCAM	Max. 41 min with PHDVM-63DM cassette
Fast forward/Rewind time		Approx. 1 min 45 s with PHDVM-63DM cassette (AC adaptor)
		Approx. 2 min 40 s with PHDVM-63DM cassette (battery pack)
Input/Output connectors		
Audio/Video output		A/V OUT jack, 10-pin connector Composite video: 1 Vp-p, 75 Ω unbalanced, sync negative Y: 1 Vp-p, 75 Ω unbalanced C: 0.286 Vp-p (burst signal), 75 Ω unbalanced Audio: 461 mV input impedance more than 47 kΩ, output impedance less than 2.2 kΩ
Component video output		COMPONENT OUT jack Y: 1 Vp-p, 75Ω unbalanced Pr/Pb (Cr/Cb): 700 mVp-p, 75Ω unbalanced
HDV/DV input/output		i.LINK interface (IEEE 1394, 4-pin connector S100)
XLR audio input		XLR 3-pin female x 2, 327 mV, -60 dBu: 3 kΩ, +4 dBu: 10 kΩ, power supply: approx. 48 V
Headphone		Stereo mini jack (φ3.5 mm)
LANC		Stereo mini-mini jack (φ2.5 mm)
USB		Mini-B connector
HDMI output		HDMI connector
Built-in output devices		
LCD viewfinder		0.54-inch** type, approx. 252,000 dots, 16:9 aspect ratio
LCD monitor		3.5-inch** type, Clear Photo LCD plus , approx. 211,200 dots, hybrid type, 16:9 aspect ratio
Speaker		φ16mm
General		
Mass		Approx. 1.5 kg (3 lb 6 oz) (camcorder only)
Power requirements		DC 7.2 V (battery pack), DC 8.4 V (AC adaptor)
Power consumption	HDV	Approx. 6.8 W (recording mode with LCD viewfinder or monitor on)
	DVCAM/DV	Approx. 6.6 W (recording mode with LCD viewfinder or monitor on)
Operating temperature		0 to 40 °C (32 to 104 °F)
Storage temperature		-20 to +60 °C (-4 to +140 °F)
Supplied accessories		AC-L15 AC adaptor Power cord NP-F570 infoLITHIUM rechargeable battery pack A/V connecting cable, component video cable, USB cable lens hood with lens cover RMT-831 wireless Remote Commander™ ECM-NV1 monaural electrolet condenser microphone Operating instructions(CD-ROM) Printed operation instructions

\* These values are calculated to be equivalent to the 35 mm film.

\*\* Viewable area, measured diagonally.

## Distributed by

© 2006 Sony Corporation. All rights reserved.  
 Reproduction in whole or in part without permission is prohibited.  
 Features and specifications are subject to change without notice.  
 All non-metric weights and measurements are approximate.  
 Sony, DVCAM, ClearVid CMOS Sensor, Enhanced Imaging Processor, DigitalMaster, SteadyShot, i.LINK, InfoLITHIUM, Memory Stick Duo, and their respective logos are trademarks of Sony Corporation.  
 Picture Profile, Shot Transition, Clear Photo LCD plus, Cinematone Gamma, and Cinematone Color are trademarks of Sony Corporation.  
 3 ClearVid CMOS Sensor logo is a trademark of Sony Corporation.  
 HDV and the HDV logo are trademarks of Sony Corporation and Victor Company of Japan, Limited.  
 Vario-Sonnar T\* is a trademark of Carl Zeiss AG.